

SELEC

MFM376 SERIES
Operating Instructions

OP506-V03



96 x 96

SPECIFICATIONS

DISPLAY

3 Row of 4 Digits
7 Segment LED Display 0.49 inch Height Digit
Integrated with parameter Units

WIRING INPUT

3 Ø - 4 wire, 3 Ø - 3 wire, 2 Ø - 3 wire and 1 Ø - 2 wire
(R/Y/B Programmable)

RATED INPUT VOLTAGE

11 to 300V AC (L-N); 19 to 519V AC (L-L)
Installation Category III (600V)

FREQUENCY RANGE

45-65 Hz

RATED INPUT CURRENT

Nominal 5A AC (Min-14mA, Max-6A)

BURDEN

0.5VA @ 5A per phase

CT PRIMARY

1A / 5A to 10,000A (Programmable for any value)
Note : 1A to 10,000A if CT secondary is 1 else
5A to 10,000A

CT SECONDARY

1A or 5A (programmable)

PT PRIMARY

100V to 500kV (Programmable for any value)

PT SECONDARY

100 to 500V (Programmable for any value)

DISPLAY UPDATE TIME

1 sec. for all parameters

DISPLAY SCROLLING

Auto / Manual / Default

POWER CONSUMPTION

Less than 8VA

ENVIRONMENTAL CONDITIONS

- Indoor use
- Altitude of up to 2000 meters
- Pollution degree II

Temperature : Operating : -10°C to 55°C
Storage : -20°C to 75°C

Humidity : Up to 85% non-condensing

MOUNTING : Panel mounting

WEIGHT

MFM376-230V AC : 260gms
MFM376-C / MFM376-C-CE : 230gms

OUTPUT

Pulse Output : Voltage range : External 24V DC max.
Current capacity : 100 mA max

Pulse Width : 100ms ± 5ms.

ORDER CODE INFORMATION

Product	Supply	Certification	
		CE	UL/US LISTED
MFM376-230VAC	240V AC, ±20%, 50/60Hz	—	—
MFM376-C	40V - 270V DC, 85V - 270V AC, 50/60Hz	—	—
MFM376-C-CE	40V - 270V DC, 85V - 270V AC, 50/60Hz	■	—

Installation Category III

ACCURACY

Measurement	Accuracy
Voltage V_{L-N}	±0.5% of Full scale
Voltage V_{L-L}	±0.5% of Full scale
Current	±0.5% of Full scale
Frequency	±0.1% For L-N Voltage >20V, For L-L Voltage >35V
Active Power	1%
Apparent power	1%
Reactive Power	1%
Power Factor	±0.01
Active Energy	Class 1
Reactive Energy	Class 1
Apparent Energy	Class 1

RESOLUTION :

PT Ratio x CT Ratio	kWh / kVAh / kVArh	Pulse	INT
<40	0.01K	0.01K	0.001K
<400	0.1K	0.1K	0.01K
<4000	1K	1K	0.1K
<40000	0.01M	0.01M	1K
<400000	0.1M	0.1M	0.01M
≥4000000	1M	1M	0.1M

Note : a) For voltage, current and power resolution is automatically adjusted
b) For power factor resolution is 0.001
c) • Blinks indicating accumulation of energy, if load is connected on any one phase of 3 Phase.

SAFETY PRECAUTIONS

All safety related codifications, symbols and instructions that appear in this operating manual or on the equipment must be strictly followed to ensure the safety of the operating personnel as well as the instrument.

If the equipment is not used in a manner specified by the manufacturer it might impair the protection provided by the equipment.

- Do not use the equipment if there is any mechanical damage.
- Ensure that the equipment is supplied with correct voltage.

CAUTION :

1. Read complete instructions prior to installation and operation of the unit.
2. Risk of electric shock.
3. The equipment in its installed state must not come in close proximity to any heating sources, oils, steam, caustic vapors or other unwanted process by products.

WIRING GUIDELINES

WARNING :

1. To prevent the risk of electric shock, power supply to the equipment must be kept OFF while doing the wiring arrangement.
2. Wiring shall be done strictly according to the terminal layout. Confirm that all connections are correct.
3. Use lugged terminals.
4. To reduce electromagnetic interference use of wires with adequate ratings and twists of the same in equal size shall be made with shortest connections.
5. Layout of connecting cables shall be away from any internal EMI source.
6. Cable used for connection to power source, must have a cross section of 0.5mm² to 2.5mm² (20 to 14AWG ; 75°C(min)). These wires shall have current carrying capacity of 6A.
7. Copper cable should be used (Stranded or Single core cable).
8. Before attempting work on device, ensure absence of voltages using appropriate voltage detection device.

INSTALLATION GUIDELINES

CAUTION :

1. This equipment, being built-in-type, normally becomes a part of main control panel and in such case the terminals do not remain accessible to the end user after installation and internal wiring.
2. Conductors must not come in contact with the internal circuitry of the equipment or else it may lead to a safety hazard that may in turn endanger life or cause electrical shock to the operator.
3. Circuit breaker or mains switch must be installed between power source and supply terminals to facilitate power 'ON' or 'OFF' function. However this switch or breaker must be installed in a convenient position normally accessible to the operator.
4. Before disconnecting the secondary of the external current transformer from the equipment, make sure that the current transformer is short circuited to avoid risk of electrical shock and injury.
5. The equipment shall not be installed in environmental conditions other than those mentioned in this manual.
6. The equipment does not have a built-in-type fuse. Installation of external fuse of rating 275V AC / 0.5Amp for electrical circuitry / battery is highly recommended.

MECHANICAL INSTALLATION

For installing the meter

1. Prepare the panel cutout with proper dimensions as shown below.
2. Push the meter into the panel cutout. Secure the meter in its place by fitting the clamp on the rear side. fit clamps on both sides in diagonally opposite location for optimum fitting.
3. For proper sealing, tighten the screws evenly with required torque.

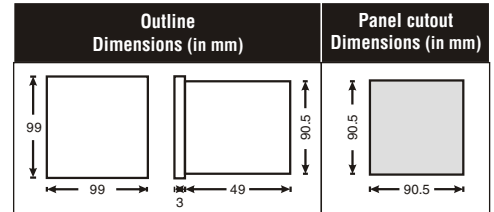

MAINTENANCE

1. The equipment should be cleaned regularly to avoid blockage of ventilating parts.
2. Clean the equipment with a clean dry or damp cloth. Do not use any cleaning agent other than water.

TERMINAL CONNECTIONS

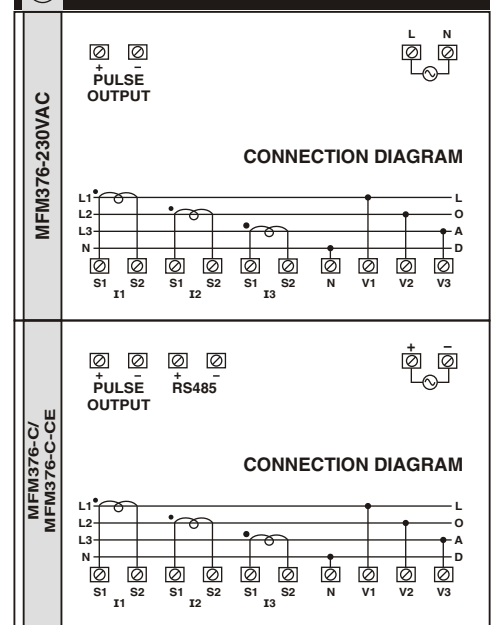

FRONT PANEL DESCRIPTION

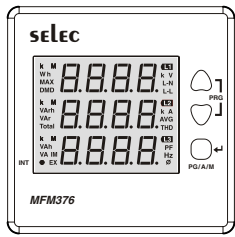

ONLINE PAGE DESCRIPTION

There are three dedicated keys labelled as Δ , ∇ and \circ . Use these 3 keys to read parameters. Simply press these keys to read the parameters. Units of corresponding parameters on display will glow automatically. Use ∇ key to go back to previous page in sub page.

For MFM376-230VAC		
KEY PRESS	ONLINE PAGE DESCRIPTION	
—	1st screen	Displays three phase average line to neutral voltage, current and power factor.
Press " Δ "	2nd screen	Displays three phase average line to line voltage, current and frequency.
	3rd screen	Displays three phase current.
	4th screen	Displays three phase line to neutral voltage.
	5th screen	Displays three phase line to line voltage.
Note : 1) For 3 phase 3 wire, only second, third and fifth screen will be available. 2) For 1 phase 2 Wire displays only voltage, Current and Power factor of selected phase in one screen.		
Press "PAGE"	1st screen	Displays three phase active power.
Press " Δ "	2nd screen	Displays three phase reactive power.
	3rd screen	Displays three phase apparent power.
	4th screen	Displays three phase total active power, reactive power, apparent power.
	Note : 1) For 3 phase 3 wire, only forth screen will be available. 2) For 1 phase 2 Wire displays only active, reactive and apparent power of selected phase in one screen.	
Press "PAGE"	1st screen	Displays three phase power factor.
Press " Δ "	2nd screen	Displays three phase phase angle.
	3rd screen	Displays active, reactive and apparent maximum power demand of three phase.
	4th screen	Displays active and reactive minimum power demand of three phase.
	Note : 1) For 3 phase 3 wire only first, third and forth screen will be available. (In first screen only average power factor will be available) 2) For 1 phase 2 wire only selected phase parameters will be displayed.	

KEY PRESS	ONLINE PAGE DESCRIPTION	
Press "PAGE"	1st screen	Displays three phase total active energy.
Press " Δ "	2nd screen	Displays three phase total reactive energy.
	3rd screen	Displays three phase total apparent energy.
	4th screen	Displays Run hour.
	5th screen	Displays Auxiliary Interrupts.

For MFM376-C / MFM376-C-CE

KEY PRESS	ONLINE PAGE DESCRIPTION	
—	1st screen	Displays three phase line to neutral voltage.
Press " Δ "	2nd screen	Displays three phase line to line voltage.
	3rd screen	Displays total percentage harmonics of line to neutral voltage of three phase.
	4th screen	Displays total percentage harmonics of line to line voltage of three phase.
	5th screen	Displays three phase instantaneous line to neutral voltage.
	6th screen	Displays three phase instantaneous line to line voltage.
	Note : 1) For 3 phase 3 wire, only second, forth and sixth screen will be available. 2) For 1 phase 2 Wire, only first, third and fifth screen of selected phase will be available.	
Press "PAGE"	1st screen	Displays three phase current.
Press " Δ "	2nd screen	Displays total percentage harmonics of current of three phase
	3rd screen	Displays active, reactive and apparent power of first phase.
	4th screen	Displays active, reactive and apparent power of second phase.
	5th screen	Displays active, reactive and apparent power of third phase.
	6th screen	Displays total active, reactive and apparent power of three phase.
	7th screen	Displays active, reactive and apparent maximum power demand of three phase.
	8th screen	Displays active and reactive minimum power demand of three phase.
	Note : 1) For 3 phase 3 wire, only first, second, sixth, seventh and eighth screen will be available. 2) For 1 phase 2 Wire, only first, second, third, seventh and eighth screen of selected phase will be available.	
Press "PAGE"	1st screen	Displays three phase instantaneous current.
Press " Δ "	2nd screen	Displays three phase power factor.
	3rd screen	Displays three phase phase angle.
	4th screen	Displays three phase average line to neutral voltage, current and power factor.

KEY PRESS	ONLINE PAGE DESCRIPTION	
Press " Δ "	5th screen	Displays three phase average line to line voltage, current and frequency.
Note : 1) For 3 phase 3 wire, only first screen, average power factor, fifth screen will be available. 2) For 1 phase 2 Wire, only first, second and third screen of selected phase will be available.		
Press "PAGE"	1st screen	Displays three phase maximum demand of current.
Press " Δ "	2nd screen	Displays import active energy.
	3rd screen	Displays export active energy.
	4th screen	Displays total active energy.
	5th screen	Displays import reactive energy.
	6th screen	Displays export reactive energy.
	7th screen	Displays total reactive energy.
	8th screen	Displays total apparent energy.
	9th screen	Displays Run Hour.
	10th screen	Displays Auxiliary interrupts.
	Note : 1) For 3 phase 3 wire, all screens will be available. 2) For 1 phase 2 wire, all screens of selected phase will be available.	

SERIAL NUMBER DESCRIPTION

Press ∇ and \circ key for 10sec to display serial no for 5sec.

AUTOMATIC / MANUAL / DEFAULT MODE

Press \circ key for 3sec to toggle between **AUTOMATIC / MANUAL / DEFAULT MODE**.

In **AUTOMATIC MODE**, only first screen of all pages will be scrolled.

In **MANUAL MODE**, the page will be change only after any key is pressed.

In **DEFAULT MODE**, Total kWh page will be displayed if any key is not pressed for 36 seconds.

PHASE DETECTION

Press \circ key for 3sec displays voltage sequence detection on last row and on last two rows for 3P4W and 3P3W only.

CT ERROR

Press ∇ key for 3sec displays current direction detection on last row. (Not applicable for 3 phase 3 wire)

RUN HOUR SELECTION

For Zero Run Hour Selection : Run Hour is ON Hour
 For Non zero Run Hour Selection: Parameter selectable between 1% to 10% will act as ON Hour.

CONFIGURATION

There are three dedicated keys with symbol Δ , ∇ & \circ . Use these 3 keys to enter into configuration menu
Note : Setting should be done by professional after going through this user manual and having understood the application situation.

For the configuration setting mode :

- Use Δ + ∇ key for 3 sec to enter and exit from configuration menu.
- Use ∇ key to shift parameter value in edit mode .
- Use Δ key to increment the parameter and for roll over. (Only if parameter is in edit mode)
- Use \circ key to save the parameter value & go to next page.
- Press ∇ key and use \circ key to go back to previous page.

To set value of PT and CT Primary in "K", first set the value in division of 100 which one want to set. (i.e. If want to set 500k then set 5000) then press ∇ key for 3 sec. It will shift the value in K with 0.1 resolution i.e. 500.0 with "K" symbol.

Config page.	Function	Range or Selection	Factory Setting
	Password	0000 to 9998	1000
1	Change Password	No / Yes	No
1.1	New Password	0000 to 9998	10
2	Network Selection	3P4W / 3P3W / 1P2W-R/1P2W-Y / 1P2W-B	3P4W
3	CT Secondary	5 / 1	5
4	CT Primary	5 to 10,000	5
5	PT Secondary	100 to 500	350
6	PT primary	100 to 500k	350
7	Demand Interval Method	Sliding/Fixed	Sliding
8	Demand Interval Duration	1 to 30	15
9	Demand interval length	1 to 30	1
10	Pulse Weight	0.01 to 99.99	0.01
11	Pulse Duration	0.1 to 2.0	0.1
12	Run Hour Selection	0 to 10	0
*13	Slave Id	1 to 255	1
*14	Baud Rate	300, 600, 1200, 2400, 4800, 9600 and 19200 (bps)	9600
*15	Parity	None, Odd, Even	None
*16	Stop Bit	1 or 2	1
17	Factory Default	Yes / No	No
18	Reset Energy and Max Dmd	Yes / No	No
18.1	Password	0001 to 9999	1001
18.01	Reset kWh	Yes / No	No
18.02	Rest kVAh	Yes / No	No
18.03	Reset kVAh	Yes / No	No
18.04	Reset MAX	Yes / No	No
18.05	Reset Run Hour	Yes / No	No
18.06	Reset Interrupt	Yes / No	No

- For resetting energy parameter user will be promoted for password. If correct password is entered. User will be able to reset all energy parameters. This password will be value which will be greater than the configuration password by 1
- * Marked values are only valid for MFM376-C/MFM376-C-CE.

NETWORK SELECTION AND WIRING INPUT

Network selection in configuration mode	Wiring
3P4W	3P4W, 2P3W, 1P2W
3P3W	3P3W
1P2W	1P2W-R, 1P2W-Y, 1P2W-B

APPLICATION OF PULSE OUTPUT

● PROCESS INTEGRATION

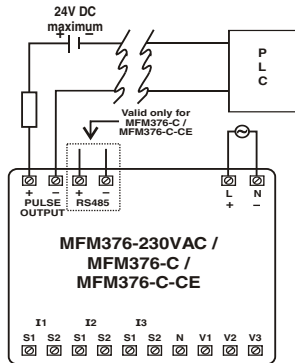

Pulse output from MFM376-230VAC / MFM376-C / MFM376-C-CE meter can be interfaced into a process through a PLC for on line control of energy content in the process.

If the PLC has a self excited digital input, external DC supply is not needed.

The kWh pulse is also used to derive average kWh information at the PLC.

● ENERGY CONTROLLER

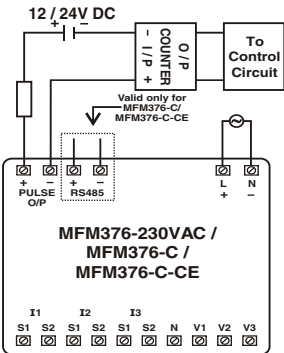

Pulse output from MFM376-230VAC / MFM376-C / MFM376-C-CE meter can be used as alarm generator or total energy controller by interfacing it with Pre-settable counter and control circuits (Contactors, Relay, Trip Circuit).

The counter is loaded with the maximum energy consumption. When count reaches setpoint it provides output to control circuit to take appropriate action.

Note : + and - is applicable only for MFM376-C/MFM376-C-CE

MODBUS REGISTER ADDRESSES LIST

Readable parameters for Communication valid only for MFM376-C / MFM376-C-CE : [Length (Register) : 2 ; Data Structure : Float]

Address	Hex Address	Parameter
30000	0x00	Voltage V1N
30002	0x02	Voltage V2N
30004	0x04	Voltage V3N
30006	0x06	Average Voltage LN
30008	0x08	Voltage V12
30010	0x0A	Voltage V23
30012	0x0C	Voltage V31
30014	0x0E	Average Voltage LL
30016	0x10	Current I1
30018	0x12	Current I2
30020	0x14	Current I3
30022	0x16	Average Current
30024	0x18	kW1
30026	0x1A	kW2
30028	0x1C	kW3
30030	0x1E	kVAr1
30032	0x20	kVAr2
30034	0x22	kVAr3
30036	0x24	kVA1
30038	0x26	kVA2
30040	0x28	kVA3
30042	0x2A	PF 1
30044	0x2C	PF 2
30046	0x2E	PF 3
30048	0x30	Average PF
30050	0x32	Frequency
30052	0x34	Total KW
30054	0x36	Total KVAR
30056	0x38	Total KVA
30058	0x3A	MAX Active Power
30060	0x3C	MIN Active Power
30062	0x3E	MAX Reactive Power
30064	0x40	MIN Reactive Power
30066	0x42	MAX Apparent Power
30068	0x44	MAX Instantaneous voltage V1N
30070	0x46	MAX Instantaneous voltage V2N
30072	0x48	MAX Instantaneous voltage V3N
30074	0x4A	MAX Instantaneous voltage V12
30076	0x4C	MAX Instantaneous voltage V23
30078	0x4E	MAX Instantaneous voltage V31
30080	0x50	MAX Instantaneous current I1
30082	0x52	MAX Instantaneous current I2
30084	0x54	MAX Instantaneous current I3
30086	0x56	Import Active energy
30088	0x58	Export Active energy
30090	0x5A	Total Active energy
30092	0x5C	Import Reactive energy
30094	0x5E	Export Reactive energy
30096	0x60	Total Reactive energy
30098	0x62	Total Apparent energy
30100	0x64	Run Hour
30102	0x66	Auxillary Interrupts
		Total Harmonic Distortion(THD)

Formula to find address of individual Harmonic

Constant Parameter	Meaning	
0	Voltage V1N	{143 + [(Harmonic no-2) x 2] + 60 x Constant Parameter }
1	Voltage V2N	For Example,
2	Voltage V3N	To find the 14 th Harmonic address of Voltage V31.
3	Voltage V12	Following formula can be used :
4	Voltage V23	Formula with the parameter :
5	Voltage V31	{143 + [(Harmonic no-2) x 2] + 60 x C P }
6	Current I1	Eg. {143 + [(14-2) x 2] + 60 x 5} = 467
7	Current I2	So, Check the 14 th Harmonic of Voltage V31 at 467 address.
8	Current I3	

Address	Hex Address	Parameter
30124	0x7C	THD of Voltage V1N
30126	0x7E	THD of Voltage V2N
30128	0x80	THD of Voltage V3N
30130	0x82	THD of Voltage V12
30132	0x84	THD of Voltage V23
30134	0x86	THD of Voltage V31
30136	0x88	THD of Current I1
30138	0x8A	THD of Current I2
30140	0x8C	THD of Current I3
30684	0x2AC	Serial number of unit

Readable / writable parameters for Communication valid only for MFM376-C / MFM376-C-CE :

Address	Hex Address	Parameter	Range		Length (Register)	Data Structure
			Min value	Max value		
40000	0x00	Password	Min value : 0	Max value : 9998	1	Integer
40001	0x01	N/W selection	Value : 0	Meaning : 3P-4W	1	Integer
			Value : 1	Meaning : 3P-3W	1	Integer
			Value : 2	Meaning : 1P2W-P1	1	Integer
			Value : 3	Meaning : 1P2W-P2	1	Integer
			Value : 4	Meaning : 1P2W-P3	1	Integer
40002	0x02	CT Secondary (A)	Min Value : 1	Max Value : 5	1	Integer
40003	0x03	CT primary (CT Secondary = 5) (A)	Min Value : 5	Max Value : 10000	1	Integer
			CT primary (CT Secondary = 1) (A)	Min Value : 1	Max Value : 10000	
40004	0x04	PT Secondary (V)	Min Value : 100	Max Value : 500	1	Integer
40005	0x05	PT primary (V)	Min Value : 100	Max Value : 500000	2	Integer
40007	0x07	Demand Interval Method	Value : 0x0000	Meaning : Sliding	1	Integer
			Value : 0x0001	Meaning : Fixed	1	Integer
40008	0x08	Demand Interval Length(min)	Min Value : 1	Max Value : 30	1	Integer
40009	0x09	Demand Interval Duration	Min Value : 1	Max Value : 30	1	Integer
40010	0x0A	Pulse Weight	Min Value : 0.01	Max Value : 99.99	1	Integer
40011	0x0B	Pulse Duration	Min Value : 0.1	Max Value : 2.0	1	Integer
40012	0x0C	Run Hour Selection	Min Value : 0	Max Value : 10	1	Integer
40013	0x0D	Slave ID	Min Value : 1	Max Value : 255	1	Integer
			Value	Meaning		
40014	0x0E	Baud rate	0x0000	300	1	Integer
			0x0001	600		
			0x0002	1200		
			0x0003	2400		
			0x0004	4800		
			0x0005	9600		
			0x0006	19200		
40015	0x0F	Parity	0x0000	None	1	Integer
			0x0001	Odd		
			0x0002	Even		
40016	0x10	Stop bit	0x0000	1	1	Integer
			0x0001	2		
40017	0x11	Factory Default	1	Set to factory setting range	1	Integer
40018	0x12	Reset kWh	1	Reset Total Active Energy	1	Integer
40019	0x13	Reset kVAh	1	Reset Total Apparent Energy	1	Integer
40020	0x14	Reset kVAh	1	Reset Total Reactive Energy	1	Integer
40021	0x15	Reset MAX Demand	1	Reset Maximum Demand	1	Integer
40022	0x16	Reset Run Hour	1	Reset Run Hour	1	Integer
40023	0x17	Reset Interrupts Count	1	Reset Auxillary Interrupt Count	1	Integer

TYPICAL WIRING DIAGRAM

3 PHASE 4-WIRE (COMMONLY USED)

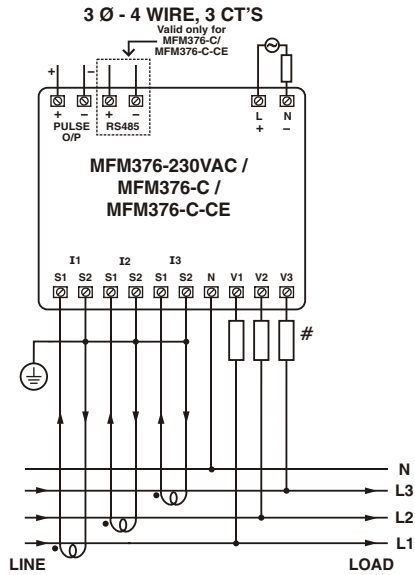

3 PHASE 3-WIRE

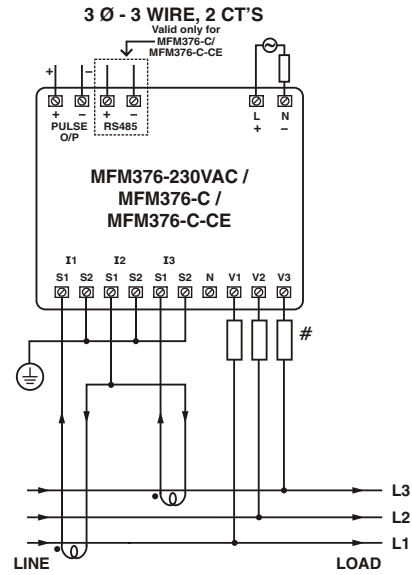

2 PHASE - 3 WIRE

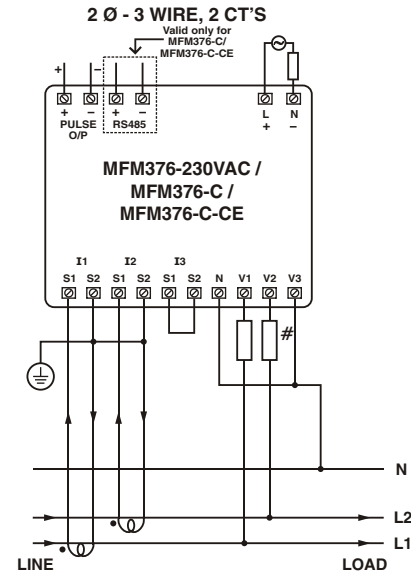

1 PHASE - 2 WIRE

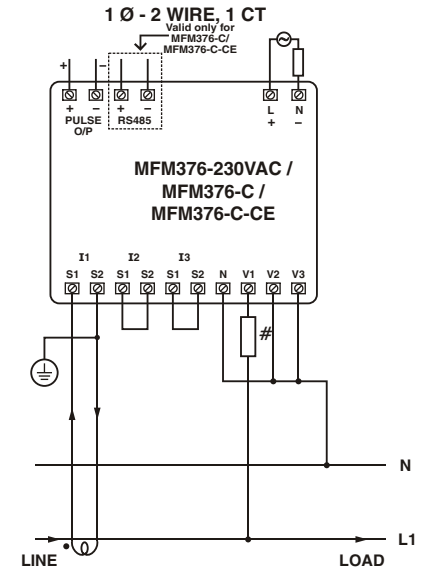

3 Ø - 4 WIRE, 3 CT'S and 3 PT'S

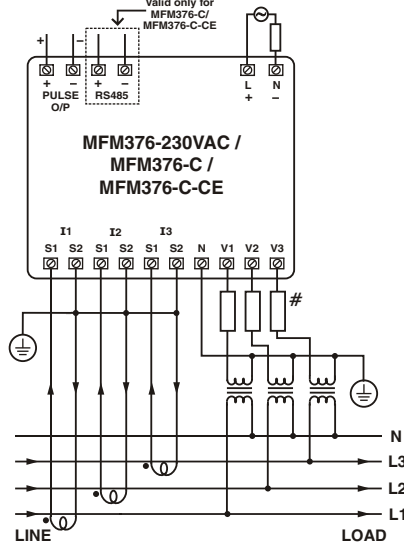

3 Ø - 3 WIRE, 2 CT'S and 2 PT'S

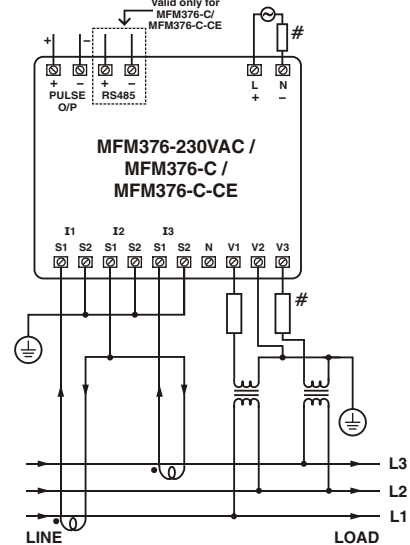

2 Ø - 3 WIRE, 2 CT'S and 2 PT'S

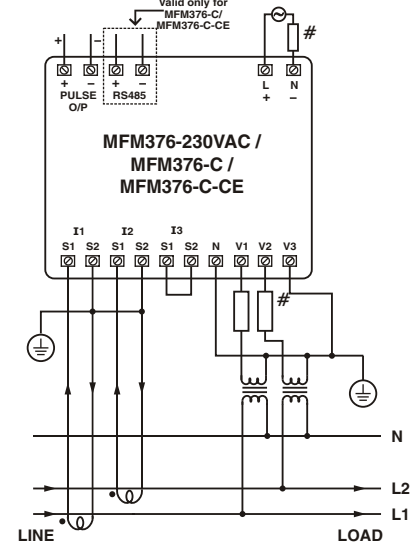

CONNECTION DIAGRAM FOR COMMUNICATION VALID ONLY FOR MFM376-C / MFM376-C-CE

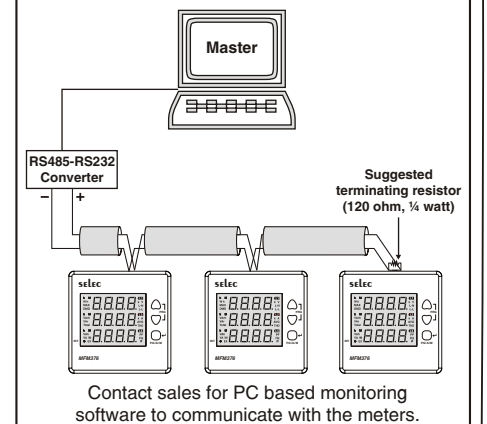

Note : + and - is applicable only for MFM376-C/MFM376-C-CE

All fuse types: 0.5A class CC UL type 0.5A fast acting 600V

(Specifications are subject to change, since development is a continuous process.)

Selec Controls Pvt. Ltd., India

Factory Address :
EL-27/1, Electronic Zone, TTC Industrial Area, MIDC, Mahape,
Navi Mumbai - 400 710, INDIA.
Tel. No. : +91-22-41 418 419/430 | Fax No. : +91-22-28471733
Toll free : 1800 227 353 (BSNL/MTNL Subscribers only)
Website : www.selec.com | Email : sales@selec.com