



**SPECIFICATIONS**

**DISPLAY**

Liquid crystal display with backlight  
1 line, 4 digits and 2 line, 7 digits per line to show electrical Parameters

**LCD INDICATIONS**

↔ - Communication in progress

**LED INDICATIONS**

INT - Integration of energy

**WIRING INPUT**

3 Ø - 4 wire, 1 Ø - 2 wire

**RATED INPUT VOLTAGE**

60 to 300V AC, 104 to 520V AC

**FREQUENCY RANGE**

45-65 Hz

**NO. OF CHANNEL**

4 Channel( 3 Ø ) ; 12 Channel(1 Ø)

**CT PRIMARY (For All Channel)**

1A to 10,000A (Programmable for any Value)

**CT SECONDARY**

330mV

**PT PRIMARY**

100V to 10kV (Programmable for any value)

**PT SECONDARY**

100 to 500V AC (L-L)(Programmable for any value)

**DISPLAY UPDATE TIME**

1sec for all parameters

**DISPLAY SCROLLING**

Automatic / Manual

**POWER CONSUMPTION**

Less than 8VA

**ENVIRONMENTAL CONDITIONS**

- Indoor use
- Altitude of up to 2000 meters
- Pollution degree II

Temperature : Operating : -10°C to 55°C  
Storage : -20°C to 75°C

Humidity : Up to 85% non-condensing

**MOUNTING**

Din Rail mounting

**WEIGHT**

290gms

ORDER CODE INFORMATION		
Product	Supply	Certification
	Self Supplied(V1,N)	CE
MRJ4M-QUAD	60 to 300V AC, 50/60Hz	■
SERIAL COMMUNICATION		
Interface standard and protocol	RS485 AND MODBUS RTU	
Communication address	1 to 255	
Transmission mode	Half duplex	
Data types	Float and Integer	
Transmission distance	500 Metre maximum	
Transmission speed	300, 600,1200, 2400, 4800, 9600,19200 (in bps)	
Parity	None, Odd, Even	
Stop bits	1 or 2	

RESOLUTION			
PT Ratio x CT Ratio	kWh	INT	
<15	0.01K	0.001K	
<150	0.1K	0.01K	
<1500	1K	0.1K	
<15000	0.01M	1K	
<150000	0.1M	0.01M	
≤1000000	1M	0.1M	

**NOTE :** 1) For Voltage, Power, resolution is automatically adjusted  
2) For Power Factor, resolution is 0.01

ACCURACY :	
Measurement	Accuracy
Voltage $V_{L-N}$	0.5   of full range
Voltage $V_{L-L}$	0.5   of full range
Current	0.5   of full range
Frequency For L-N Voltage >20V, For L-L Voltage >35V	0.1   of full range
Active Power	1.0   of full range
Reactive Power	1.0   of full range
Apparent Power	1.0   of full range
Power Factor	±0.01 of full range
Active Energy	1.0   of full range
Reactive Energy	1.0   of full range
Apparent Energy	1.0   of full range

**SAFETY PRECAUTIONS**

All safety related codifications, symbols and instructions that appear in this operating manual or on the equipment must be strictly followed to ensure the safety of the operating personnel as well as the instrument.

If the equipment is not used in a manner specified by the manufacturer it might impair the protection provided by the equipment.

- Do not use the equipment if there is any mechanical damage.
- Ensure that the equipment is supplied with correct voltage.

**CAUTION :**

1. Read complete instructions prior to installation and operation of the unit.
2. Risk of electric shock.
3. The equipment in its installed state must not come in close proximity to any heating sources, oils, steam, caustic vapors or other unwanted process by products.

**WIRING GUIDELINES**

**WARNING :**

1. To prevent the risk of electric shock, power supply to the equipment must be kept OFF while doing the wiring arrangement.
2. Wiring shall be done strictly according to the terminal layout. Confirm that all connections are correct.
3. Use lugged terminals.
4. To reduce electromagnetic interference use of wires with adequate ratings and twists of the same in equal size shall be made with shortest connections.
5. Layout of connecting cables shall be away from any internal EMI source.
6. Copper cable should be used ( Stranded or Single core cable).
7. Before attempting work on device, ensure absence of voltages using appropriate voltage detection device.

**INSTALLATION GUIDELINES**

**CAUTION :**

1. Conductors must not come in contact with the internal circuitry of the equipment or else it may lead to a safety hazard that may in turn endanger life or cause electrical shock to the operator.
2. Circuit breaker or mains switch must be installed between power source and supply terminals to facilitate power 'ON' or 'OFF' function. However this switch or breaker must be installed in a convenient position normally accessible to the operator.
3. Before disconnecting the secondary of the external current transformer from the equipment, make sure that the current transformer is short circuited to avoid risk of electrical shock and injury.
4. The equipment shall not be installed in environmental conditions other than those mentioned in this manual.
5. The equipment does not have a built-in-type fuse. Installation of external fuse of rating 275V AC / 0.5Amp for electrical circuitry / battery is highly recommended.

**DIMENSIONS ( All dimensions in mm )**

**Front View**

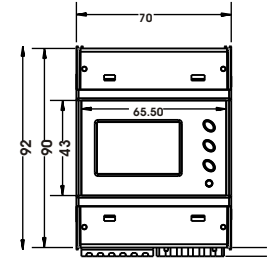

**Side View**

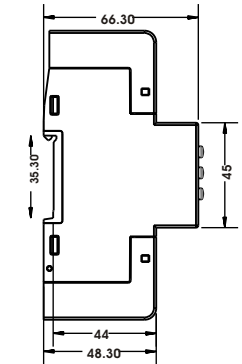

**Front View (With Cover)**

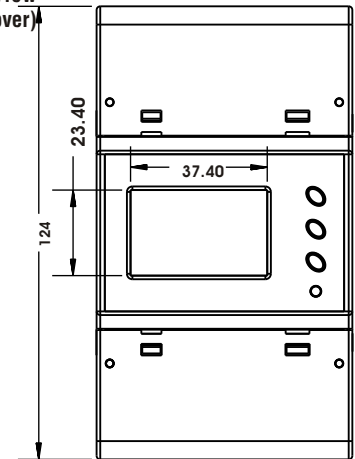

**NOTE :** Measuring current input should be connect with external CT only.

**CHANNEL DESCRIPTION**

Group	12 Channel Meter	4 Channel Meter
Gr 1	CH1, CH2, CH3	1 <sup>st</sup> , 2 <sup>nd</sup> and 3 <sup>rd</sup> phase of CH1
Gr 2	CH4, CH5, CH6	1 <sup>st</sup> , 2 <sup>nd</sup> and 3 <sup>rd</sup> phase of CH2
Gr 3	CH7, CH8, CH9	1 <sup>st</sup> , 2 <sup>nd</sup> and 3 <sup>rd</sup> phase of CH3
Gr 4	CH10, CH11, CH12	1 <sup>st</sup> , 2 <sup>nd</sup> and 3 <sup>rd</sup> phase of CH4



FIRST KEY (▷) PRESS	SECOND KEY (△) PRESS	DESCRIPTION
Press (▷) key (5th Time)		Displays line to neutral voltage and CH 11 Reactive Energy
		Displays line to neutral voltage and CH 12 Reactive Energy
		Displays line to neutral voltage and Total Reactive Energy of all channel.
Press (▷) key (6th Time)		Displays line to neutral voltage and CH 1 Apparent Energy.
		Displays line to neutral voltage and CH 2 Apparent Energy.
		Displays line to neutral voltage and CH 3 Apparent Energy.
		Displays line to neutral voltage and CH 4 Apparent Energy.
		Displays line to neutral voltage and CH 5 Apparent Energy.
		Displays line to neutral voltage and CH 6 Apparent Energy.
		Displays line to neutral voltage and CH 7 Apparent Energy.
		Displays line to neutral voltage and CH 8 Apparent Energy.
		Displays line to neutral voltage and CH 9 Apparent Energy.
		Displays line to neutral voltage and CH 10 Apparent Energy.
		Displays line to neutral voltage and CH 11 Apparent Energy.
		Displays line to neutral voltage and CH 12 Apparent Energy.
Press (▷) key (7th Time)		Displays Active Power of group 1.
		Displays Active Power of group 2.
		Displays Active Power of group 3.
		Displays Active Power of group 4.
Press (▷) key (8th Time)		Displays Reactive Power of group 1.
		Displays Reactive Power of group 2.
		Displays Reactive Power of group 3.
		Displays Reactive Power of group 4.

FIRST KEY (▷) PRESS	SECOND KEY (△) PRESS	DESCRIPTION
Press (▷) key (9th Time)	—	Displays Apparent Power of group 1.
	1st time	Displays Apparent Power of group 2.
	2nd time	Displays Apparent Power of group 3.
	3rd time	Displays Apparent Power of group 4.

#### SERIAL NUMBER DESCRIPTION

Press △ key for 10sec. to display 8 digit serial number only for 10sec. at 2nd and 3rd line of display

#### AUTO / MANUAL PAGE MODE DESCRIPTION :

Press First key for 3sec. to toggle between Automatic and Manual mode.

**Note :** By default unit operates in automatic mode. In automatic mode online pages scroll automatically at the rate of 5 sec. per page.

In automatic mode when any key is pressed, unit temporarily switches to manual mode and the appropriate page is displayed, also if any key is not pressed for 5sec., unit resumes automatic mode.

#### CONFIGURATION

There are 3 dedicated key with symbols marked as ▷, △ and ◀. Use these 3 key to enter into configuration / change setting.

**Note :** The settings should be done by a professional, after going through this users manual and after having understood the application situation.

For the configuration setting mode :

- Use △ and ◀ for 3 sec. to enter or exit from config mode
- Use ▷ shift key to move cursor left or right by one digit each time. After last digit of display cursor shift at 1st digit of display.
- Use △ increment key for increasing the parameter value.
- Use ◀ key to save the setting and move on to next page
- Use △ and ▷ keys to go back to previous page.

Config. page.	Function	Range or Selection	Factory Setting
	Password	0000 to 9998	1000
1	Change Password	No / Yes	No
1.1	New Password	0000 to 9998	0000
2	No of Channel	4 CH / 12 CH	4 CH
3	Network Selection		3P4W
	For 4 Channel	3P4W, 1P2W-P1, 1P2W-P2, 1P2W-P3.	
	For 12 Channel	1P2W	
4	CT Secondary	1	1
	For 4 Channel		
5	CT Primary CH 1	1 to 10000	1
6	CT Primary CH 2	1 to 10000	1
7	CT Primary CH 3	1 to 10000	1
8	CT Primary CH 4	1 to 10000	1
	For 12 Channel		
5	CT Primary Gr 1	1 to 10000	1
6	CT Primary Gr 2	1 to 10000	1
7	CT Primary Gr 3	1 to 10000	1
8	CT Primary Gr 4	1 to 10000	1
9	L1 CT mounting	RHS/LHS	RHS
10	L2 CT mounting	RHS/LHS	RHS
11	L3 CT mounting	RHS/LHS	RHS
12	L4 CT mounting	RHS/LHS	RHS
13	PT Secondary	100 to 500	350
14	PT primary	100 to 10000	350
15	Slave Id	1 to 255	1
16	Baud Rate	300, 600, 1200, 2400, 4800, 9600 and 19200	9600
17	Parity	None, Odd, Even	None
18	Stop Bit	1 to 2	1
19	Backlight	0000 to 7200	0000
20	Factory Default	No / Yes	No

Config. page.	Function	Range or Selection	Factory Setting
21	Reset Energy	No / Yes	No
21.1	Password	0001 to 9999	1001
21.2	Reset Kwh		None
	For 4 Channel	CH 1, CH 2, CH 3, CH 4 None and All	
	For 12 Channel	CH 1, CH 2, CH 3, CH 4, CH 5, CH 6, CH 7, CH 8, CH 9, CH 10, CH 11, CH 12 None and All	
21.3	Reset Kvarh		None
	For 4 Channel	CH 1, CH 2, CH 3, CH 4 None and All	
	For 12 Channel	CH 1, CH 2, CH 3, CH 4, CH 5, CH 6, CH 7, CH 8, CH 9, CH 10, CH 11, CH 12 None and All	
21.4	Reset Kvah		None
	For 4 Channel	CH 1, CH 2, CH 3, CH 4 None and All	
	For 12 Channel	CH 1, CH 2, CH 3, CH 4, CH 5, CH 6, CH 7, CH 8, CH 9, CH 10, CH 11, CH 12 None and All	

For resetting energy parameters user will be prompted the password. If correct password is entered, the user will be able to reset all energy parameters. This password will be value which will be greater than the configuration password by 1.

## MODBUS REGISTER ADDRESSES LIST

Readable parameters for 4 Channel Meter : [ Length (Register) : 2 ; Data Structure : Float ]

ADDRESS	HEX ADDRESS	PARAMETER
30000	0x00	1st Phase line to neutral voltage of CH 1
30002	0x02	2nd Phase line to neutral voltage of CH 1
30004	0x04	3rd Phase line to neutral voltage of CH 1
30006	0x06	Average line to neutral voltage of CH 1
30008	0x08	1st Phase line to line voltage of CH 1
30010	0x0A	2nd Phase line to line voltage of CH 1
30012	0x0C	3rd Phase line to line voltage of CH 1
30014	0x0E	Average line to line voltage of CH 1
30016	0x10	1st Phase current of CH 1
30018	0x12	2nd Phase current of CH 1
30020	0x14	3rd Phase current of CH 1
30022	0x16	Average current of CH 1
30024	0x18	Frequency
30026	0x1A	1st Phase Active Power of CH 1
30028	0x1C	2nd Phase Active Power of CH 1
30030	0x1E	3rd Phase Active Power of CH 1
30032	0x20	Total Active Power of CH 1
30034	0x22	1st Phase Reactive Power of CH 1
30036	0x24	2nd Phase Reactive Power of CH 1
30038	0x26	3rd Phase Reactive Power of CH 1
30040	0x28	Total Reactive Power of CH 1
30042	0x2A	1st Phase Apparent Power of CH 1
30044	0x2C	2nd Phase Apparent Power of CH 1
30046	0x2E	3rd Phase Apparent Power of CH 1
30048	0x30	Total Apparent Power of CH 1
30050	0x32	1st Phase Power Factor of CH 1
30052	0x34	2nd Phase Power Factor of CH 1
30054	0x36	3rd Phase Power Factor of CH 1
30056	0x38	Average Power Factor of CH 1
30058	0x3A	1st Phase Active Energy of CH 1
30060	0x3C	2nd Phase Active Energy of CH 1
30062	0x3E	3rd Phase Active Energy of CH 1
30064	0x40	Total Active Energy of CH 1
30066	0x42	1st Phase Reactive Energy of CH 1
30068	0x44	2nd Phase Reactive Energy of CH 1
30070	0x46	3rd Phase Reactive Energy of CH 1
30072	0x48	Total Reactive Energy of CH 1
30074	0x4A	1st Phase Apparent Energy of CH 1

ADDRESS	HEX ADDRESS	PARAMETER
30076	0x4C	2nd Phase Apparent Energy of CH 1
30078	0x4E	3rd Phase Apparent Energy of CH 1
30080	0x50	Total Apparent Energy of CH 1
30082	0x52	1st Phase line to neutral voltage of CH 2
30084	0x54	2nd Phase line to neutral voltage of CH 2
30086	0x56	3rd Phase line to neutral voltage of CH 2
30088	0x58	Average line to neutral voltage of CH 2
30090	0x5A	1st Phase line to line voltage of CH 2
30092	0x5C	2nd Phase line to line voltage of CH 2
30094	0x5E	3rd Phase line to line voltage of CH 2
30096	0x60	Average line to line voltage of CH 2
30098	0x62	1st Phase current of CH 2
30100	0x64	2nd Phase current of CH 2
30102	0x66	3rd Phase current of CH 2
30104	0x68	Average current of CH 2
30106	0x6A	Frequency
30108	0x6C	1st Phase Active Power of CH 2
30110	0x6E	2nd Phase Active Power of CH 2
30112	0x70	3rd Phase Active Power of CH 2
30114	0x72	Total Active Power of CH 2
30116	0x74	1st Phase Reactive Power of CH 2
30118	0x76	2nd Phase Reactive Power of CH 2
30120	0x78	3rd Phase Reactive Power of CH 2
30122	0x7A	Total Reactive Power of CH 2
30124	0x7C	1st Phase Apparent Power of CH 2
30126	0x7E	2nd Phase Apparent Power of CH 2
30128	0x80	3rd Phase Apparent Power of CH 2
30130	0x82	Total Apparent Power of CH 2
30132	0x84	1st Phase Power Factor of CH 2
30134	0x86	2nd Phase Power Factor of CH 2
30136	0x88	3rd Phase Power Factor of CH 2
30138	0x8A	Average Power Factor of CH 2
30140	0x8C	1st Phase Active Energy of CH 2
30142	0x8E	2nd Phase Active Energy of CH 2
30144	0x90	3rd Phase Active Energy of CH 2
30146	0x92	Total Active Energy of CH 2
30148	0x94	1st Phase Reactive Energy of CH 2
30150	0x96	2nd Phase Reactive Energy of CH 2

ADDRESS	HEX ADDRESS	PARAMETER
30152	0x98	3rd Phase Reactive Energy of CH 2
30154	0x9A	Total Reactive Energy of CH 2
30156	0x9C	1st Phase Apparent Energy of CH 2
30158	0x9E	2nd Phase Apparent Energy of CH 2
30160	0xA0	3rd Phase Apparent Energy of CH 2
30162	0xA2	Total Apparent Energy of CH 2
30164	0xA4	1st Phase line to neutral voltage of CH 3
30166	0xA6	2nd Phase line to neutral voltage of CH 3
30168	0xA8	3rd Phase line to neutral voltage of CH 3
30170	0xAA	Average line to neutral voltage of CH 3
30172	0xAC	1st Phase line to line voltage of CH 3
30174	0xAE	2nd Phase line to line voltage of CH 3
30176	0xB0	3rd Phase line to line voltage of CH 3
30178	0xB2	Average line to line voltage of CH 3
30180	0xB4	1st Phase current of CH 3
30182	0xB6	2nd Phase current of CH 3
30184	0xB8	3rd Phase current of CH 3
30186	0xBA	Average current of CH 3
30188	0xBC	Frequency
30190	0xBE	1st Phase Active Power of CH 3
30192	0xC0	2nd Phase Active Power of CH 3
30194	0xC2	3rd Phase Active Power of CH 3
30196	0xC4	Total Active Power of CH 3
30198	0xC6	1st Phase Reactive Power of CH 3
30200	0xC8	2nd Phase Reactive Power of CH 3
30202	0xCA	3rd Phase Reactive Power of CH 3
30204	0xCC	Total Reactive Power of CH 3
30206	0xCE	1st Phase Apparent Power of CH 3
30208	0xD0	2nd Phase Apparent Power of CH 3
30210	0xD2	3rd Phase Apparent Power of CH 3
30212	0xD4	Total Apparent Power of CH 3
30214	0xD6	1st Phase Power Factor of CH 3
30216	0xD8	2nd Phase Power Factor of CH 3
30218	0xDA	3rd Phase Power Factor of CH 3
30220	0xDC	Average Power Factor of CH 3
30222	0xDE	1st Phase Active Energy of CH 3
30224	0xE0	2nd Phase Active Energy of CH 3
30226	0xE2	3rd Phase Active Energy of CH 3

ADDRESS	HEX ADDRESS	PARAMETER
30228	0xE4	Total Active Energy of CH 3
30230	0xE6	1st Phase Reactive Energy of CH 3
30232	0xE8	2nd Phase Reactive Energy of CH 3
30234	0xEA	3rd Phase Reactive Energy of CH 3
30236	0xEC	Total Reactive Energy of CH 3
30238	0xEE	1st Phase Apparent Energy of CH 3
30240	0xF0	2nd Phase Apparent Energy of CH 3
30242	0xF2	3rd Phase Apparent Energy of CH 3
30244	0xF4	Total Apparent Energy of CH 3
30246	0xF6	1st Phase line to neutral voltage of CH 4
30248	0xF8	2nd Phase line to neutral voltage of CH 4
30250	0xFA	3rd Phase line to neutral voltage of CH 4
30252	0xFC	Average line to neutral voltage of CH 4
30254	0xFE	1st Phase line to line voltage of CH 4
30256	0x100	2nd Phase line to line voltage of CH 4
30258	0x102	3rd Phase line to line voltage of CH 4
30260	0x104	Average line to line voltage of CH 4
30262	0x106	1st Phase current of CH 4
30264	0x108	2nd Phase current of CH 4
30266	0x10A	3rd Phase current of CH 4
30268	0x10C	Average current of CH 4
30270	0x10E	Frequency
30272	0x110	1st Phase Active Power of CH 4
30274	0x112	2nd Phase Active Power of CH 4
30276	0x114	3rd Phase Active Power of CH 4
30278	0x116	Total Active Power of CH 4
30280	0x118	1st Phase Reactive Power of CH 4
30282	0x11A	2nd Phase Reactive Power of CH 4
30284	0x11C	3rd Phase Reactive Power of CH 4
30286	0x11E	Total Reactive Power of CH 4
30288	0x120	1st Phase Apparent Power of CH 4
30290	0x122	2nd Phase Apparent Power of CH 4
30292	0x124	3rd Phase Apparent Power of CH 4
30294	0x126	Total Apparent Power of CH 4
30296	0x128	1st Phase Power Factor of CH 4
30298	0x12A	2nd Phase Power Factor of CH 4
30300	0x12C	3rd Phase Power Factor of CH 4
30302	0x12E	Average Power Factor of CH 4

**MODBUS REGISTER ADDRESSES LIST**

 Readable parameters for 4 Channel Meter :  
 [ Length (Register) : 2 ; Data Structure : Float ]

ADDRESS	HEX ADDRESS	PARAMETER
30304	0x130	1st Phase Active Energy of CH 4
30306	0x132	2nd Phase Active Energy of CH 4
30308	0x134	3rd Phase Active Energy of CH 4
30310	0x136	Total Active Energy of CH 4
30312	0x138	1st Phase Reactive Energy of CH 4
30314	0x13A	2nd Phase Reactive Energy of CH 4
30316	0x13C	3rd Phase Reactive Energy of CH 4
30318	0x13E	Total Reactive Energy of CH 4
30320	0x140	1st Phase Apparent Energy of CH 4
30322	0x142	2nd Phase Apparent Energy of CH 4
30324	0x144	3rd Phase Apparent Energy of CH 4
30326	0x146	Total Apparent Energy of CH 4
30328	0x148	Serial No. (Data Structure : Hex)
30330	0x14A	Total Active Energy of all channel.
30332	0x14C	Total Reactive Energy of all channel.
30334	0x14E	Total Apparent Energy of all channel.

**MODBUS REGISTER ADDRESSES LIST**

Readable / Writable parameters from RID-480

Address	Hex Address	Parameter	Range		Length (Register)	Data Structure
			Min value	Max value		
40000	0x00	Password	0	9998	1	Integer
			Value	Meaning		
40001	0x01	N/W selection	0x0000	3P-4W	1	Integer
			0x0001		1	Integer
			0x0002	1P2W-P1	1	Integer
			0x0003	1P2W-P2	1	Integer
			0x0004	1P2W-P3	1	Integer
		(Valid only for 12 Channel meter)	0x0005	1P2W	1	Integer
			Min value	Max value		
40002	0x02	CT Secondary	1	1	1	Integer
40003	0x03	CT Primary CH1 (Gr 1 for 12 CH Meter)	1	10000	1	Integer
40004	0x04	CT Primary CH2 (Gr 2 for 12 CH Meter)	1	10000	1	Integer
40005	0x05	CT Primary CH3 (Gr 3 for 12 CH Meter)	1	10000	1	Integer
40006	0x06	CT Primary CH4 (Gr 4 for 12 CH Meter)	1	10000	1	Integer
40007	0x07	PT Secondary	100	500	1	Integer
40008	0x08	PT Primary	100	10000	2	Integer
40010	0x0A	Slave ID	1	255		
			Value	Meaning		
40011	0x0B	Baud Rate	0x0000	300	1	Integer
			0x0001	600	1	Integer
			0x0002	1200	1	Integer
			0x0003	2400	1	Integer
			0x0004	4800	1	Integer
			0x0005	9600	1	Integer
			0x0006	19200	1	Integer
40012	0x0C	Parity	0x0000	None	1	Integer
			0x0001	Odd	1	Integer
			0x0002	Even	1	Integer
40013	0x0D	Stop Bit	0x0000	1	1	Integer
			0x0001	2	1	Integer
			Min value	Max value		
40014	0x0E	Backlight	0000	7200	1	Integer
			Value	Meaning		
40015	0x0F	No of channel	0x0000	4 channel	1	Integer
			0x0001	12 channel	1	Integer
40016	0x10	Factory Default	1	To set factory setting range	1	Integer
40017	0x11	Reset Active Energy	1	CH 1	1	Integer

## MODBUS REGISTER ADDRESSES LIST

NOTE : CHANNEL 5 to CHANNEL 12 are valid only for 12 CHANNEL Meter.

Address	Hex Address	Parameter	Range	Length (Register)	Data Structure	
			2	CH 2	1	Integer
			3	CH 3	1	Integer
			4	CH 4	1	Integer
			5	CH 5	1	Integer
			6	CH 6	1	Integer
			7	CH 7	1	Integer
			8	CH 8	1	Integer
			9	CH 9	1	Integer
			10	CH 10	1	Integer
			11	CH 11	1	Integer
			12	CH 12	1	Integer
			13	Total Active Energy	1	Integer
40018	0x12	Reset Apparent Energy	1	CH 1	1	Integer
			2	CH 2	1	Integer
			3	CH 3	1	Integer
			4	CH 4	1	Integer
			5	CH 5	1	Integer
			6	CH 6	1	Integer
			7	CH 7	1	Integer
			8	CH 8	1	Integer
			9	CH 9	1	Integer
			10	CH 10	1	Integer
			11	CH 11	1	Integer
			12	CH 12	1	Integer
			13	Total Apparent Energy	1	Integer
40019	0x13	Reset Reactive Energy	1	CH 1	1	Integer
			2	CH 2	1	Integer
			3	CH 3	1	Integer
			4	CH 4	1	Integer
			5	CH 5	1	Integer
			6	CH 6	1	Integer
			7	CH 7	1	Integer
			8	CH 8	1	Integer
			9	CH 9	1	Integer
			10	CH 10	1	Integer
			11	CH 11	1	Integer
			12	CH 12	1	Integer
			13	Total Reactive Energy	1	Integer

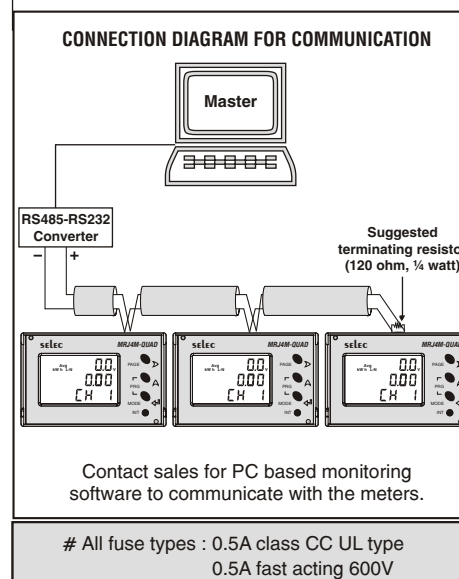
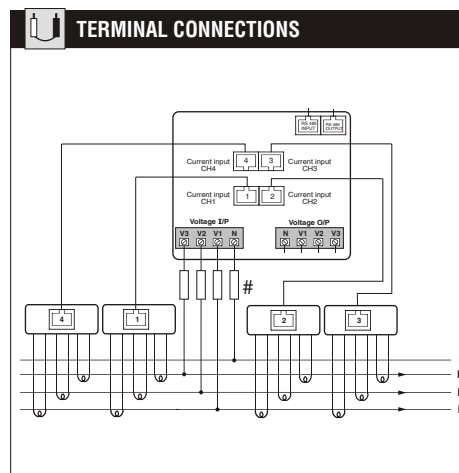

### INTERNAL PINOUT FOR COMMUNICATION RS485 PORT

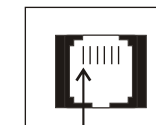

PIN 1

PIN	DESCRIPTION
1	RS485+ (Slave)
2	---
3	---
4	---
5	---
6	RS485- (Slave)

### ACCESSORIES (To be ordered separately)

ORDER CODE	DESCRIPTION
AC-USB-RS485-03	USB to RS485 cable (6 pin jack for downloading)
AC-USB-RS485-02 *	USB to RS485 cable (2 pin open wire)
ACH-004	RJ25 (6-pin) cable
AC-IOEXP-02	Port Expansion adapter

Note: \* Along with ACH-004 & AC-IOEXP-02 for networking

(Specifications subject to change as development is a continuous process.)

### Selec Controls Pvt. Ltd., India

Factory Address :  
EL-27/1, Electronic Zone, TTC Industrial Area,  
MIDC, Mahape, Navi Mumbai - 400 710, INDIA.  
Tel. No. : +91-22-28476443 / 1882  
Fax No. : +91-22-28471733 | Toll free : 1800 227 353  
Website: www.selec.com | Email: sales@selec.com