



FEATURES

- Auto / Manual mode selection
- Failsafe / Non-failsafe mode selection
- Self check mode
- Remotely controllable

SPECIFICATIONS

AUXILIARY SUPPLY

Voltage : 90-270V AC / DC
Frequency : 50-60 Hz
Power consumption : Approx. 3 Watts @230V AC
Initialization time : 3 seconds

LED INDICATIONS

1. **GREEN** : Power ON indication
2. **YELLOW** : Sensor indication
3. **RED** : Relay status

RELAY OPERATING MODES

1. Failsafe mode
2. Non-failsafe mode

RELAY OUTPUT

Type of contact : DPDT
Contact rating : 8A@250V AC
Contact material : AgSnO₂
Max switching current : 8A
Electrical life : 1x10⁵ Operations
Mechanical life : 1x10⁷ Operations

ENVIRONMENTAL

Temperature range
Operating : 0° to 55° C
Storage : -20° to 70° C
Humidity : 10% to 95% RH

MECHANICAL

Mounting : Din Rail Mounting (size 35mm)
Type of connection : Terminal screw-16A rating
Dimension : 60mm x 35mm x 90mm
Housing : 2M
Weight : 115 g
No of terminals : 11 (L, N, REMOTE, GND, PTC NO1, NC1, C1, NO2, NC2, C2)

WIRING GUIDELINES

WARNING

1. To prevent the risk of electric shock power supply to the equipment must be kept OFF while doing the wiring arrangement.
2. Wiring shall be done strictly according to the terminal layout with shortest connections. Confirm that all connections are correct.

CAUTION

1. To ensure the safe operation of unit, check the wiring and connections.
2. It is recommended to test the unit periodically to satisfy the regulations.

SAFETY PRECAUTIONS

All safety related codifications, symbols and instructions that appear in this operating manual or on the equipment must be strictly followed to ensure the safety of the operating personnel as well as the instrument.

If the equipment is not used in a manner specified by the manufacturer it might impair the protection provided by the equipment.

Read complete instructions prior to installation.

TERMINAL DIAGRAM

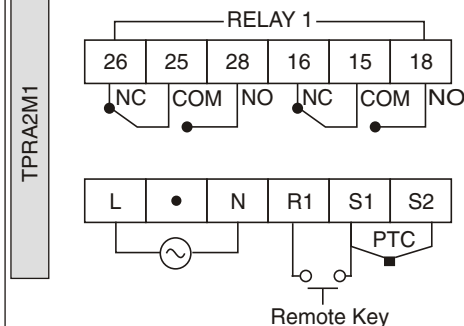

MECHANICAL INSTALLATION

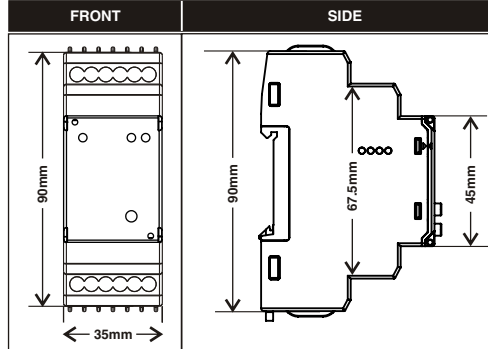

CONNECTION DIAGRAM

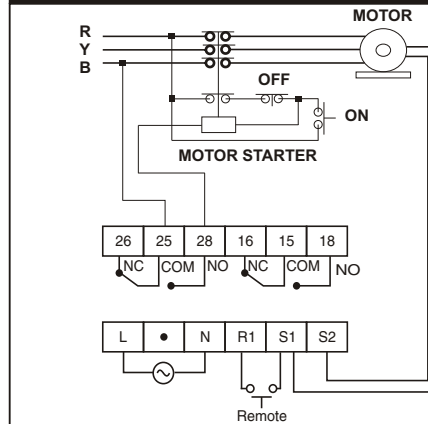

FRONT PANEL DESCRIPTION

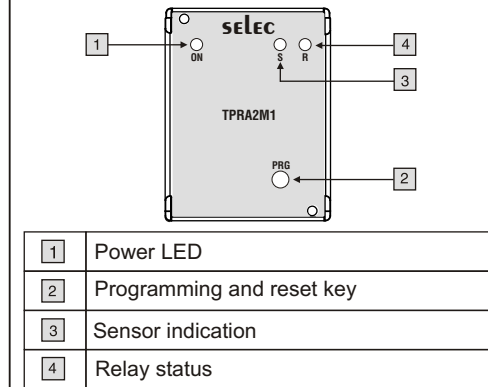

LED INDICATION

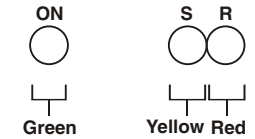

PTC SENSOR CHARACTERISTICS

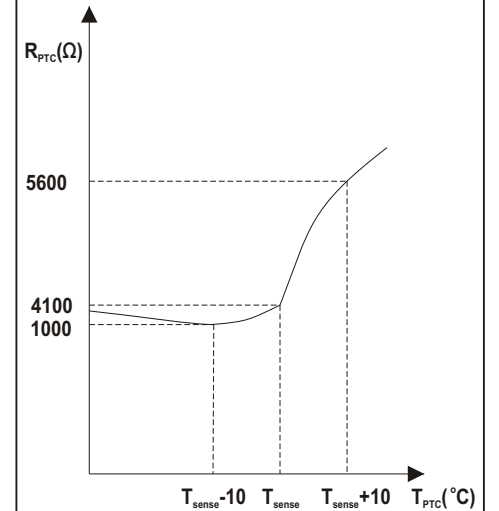

SENSOR SPECIFICATIONS

1. Sensor Short : ≤ 40Ω
2. Sensor Healthy : ≥44Ω (±3Ω) to <3.8KΩ (±150Ω)
3. Sensor Trip : ≥3.8KΩ (±150Ω) to <5.5KΩ (±150Ω)
4. Sensor Open : ≥5.5KΩ (±150Ω) & Above
5. Sensor Cut-in/Recovery : ≤1.5KΩ (±60Ω)

DESCRIPTION

Thermistor motor protection relay is used for controlling motor with the help of PTC sensors. The PTC sensor changes its resistance with respect to the temperature of motor. The resistance is measured by the thermistor motor protection relay and depending upon the sensor condition the relay is switched.

Following are the sensor conditions which are classified depending upon the resistance:

1. **Sensor Short** : Sensor is short / damaged. S-LED blinks slowly.

We can enter the programming mode only when in Sensor Short condition. To enter into the programming mode keep the PRG key pressed for 5 seconds.



2. **Sensor Healthy** : The motor is running safely. R-LED is ON in fail-safe mode & vice versa.

3. **Sensor Trip** : When the motor exceeds its temperature beyond its safety limit, it is in trip condition. The moment Trip condition is reached, the S-LED, turns on and the relay changes its state automatically. It stays in Trip condition until the motor cools down and reaches Cut-in.

Sensor Cut-in : After the motor cools down, it reaches cut-in condition. The relay switches automatically, in Auto Mode. Whereas, in Manual mode, the user has to press the front PRG key or the Remote Key, momentarily, when in Cut-in condition. Press the PRG key momentarily when R-LED is blinking.

5. **Sensor Open** : Sensor is open / break. S-Led blinks fast.



LED STATUS

●	ON
○	OFF
	Slow Blink
	Fast Blink

FUNCTIONING





1. AUTO MODE :

After cut-in the relay switches its state automatically to Healthy state.

Sensor condition	R-LED Failsafe	R-LED Non-Failsafe	S-LED
Short	○	●	
Healthy	●	○	○
Trip	○	●	●
Open	○	●	

2. MANUAL MODE :

Press the key when the R-LED starts slow blinking i.e. when the sensor condition is Cut-in. After pressing the key, the relay goes into Healthy state.

Sensor condition	R-LED Failsafe	R-LED Non-Failsafe	S-LED
Short	○	●	
Healthy	●	○	○
Trip	○	●	●
Open	○	●	
Cut-in(Key not press)			○

WARRANTY / LIMITATIONS OF LIABILITY

Selec warrants the products to be free from defects in the materials and workmanship for a period of one year (or other period specified, if any) from the date of sale by Selec.

The warranty does not apply to defects resulting from any action of the buyer, including but not limited to improper handling, operating the product outside the specification limits or unauthorized disassembling / altering of the product. The warranty shall be VOID if the product shows evidence of having been tampered or being damaged due to usage in corrosive environment ; or current, heat, moisture or vibration ; improper specification ; wrong usage in an application ; misuse or other operating conditions outside of Selec's control.

Selec shall not be responsible for special, indirect or consequential damages, loss of profits or commercial loss in any way connected with the products, whether such claim is based on contract, warranty, negligence or strict liability.





In no event shall the responsibility of Selec for any act exceed the individual price of the product on which liability is asserted.

In no event shall Selec be responsible for warranty or other claims regarding the products unless Selec's analysis confirms that the products were properly handled, stored, installed and maintained and not subject to contamination, abuse, misuse or inappropriate modification or repair.

PROGRAMMING SCHEME

To enter programming mode, short terminals S1 and S2 to go to Sensor Short condition. Make sure to remove all connections done to the relay. Now, press the PRG key for 5 seconds. Once, we enter programming mode, each mode has 10 seconds to be configured. To make changes press the front PRG key but in that time window only. After 10 seconds, it will directly go to the next mode which is indicated by fast blinking of both S & R LEDs. The changes are auto-saved and retained.

Note: Remote key can also be used for programming.

Mode	PRG key	LED indication		DURATION
		S	R	
Enter configuration	Pressed for 5 seconds			3 seconds
Relay check mode	Press key to toggle relay	ON	● : Relay ON ○ : Relay OFF	10 seconds
Next mode	NA			3 seconds
Auto / Manual selection	Press key to select mode • Auto • Manual	OFF	● : Auto ○ : Manual	10 seconds
Next mode	NA			3 seconds
Failsafe & Non-failsafe selection	Press key to select mode • Failsafe • Non-Failsafe mode		● : Failsafe ○ : Non-failsafe	10 seconds

(Specifications are subject to change, since development is a continuous process.)

Selec Controls Pvt. Ltd., India

Factory Address :
EL-27/1, Electronic Zone, TTC Industrial Area, MIDC, Mahape,
Navi Mumbai - 400 710, INDIA.
Tel. No. : +91-22-41 418 468/452 | Fax No. : +91-22-28471733
Toll free : 1800 227 353 (BSNL/MTNL Subscribers only)
Website : www.selec.com | Email : sales@selec.com

ORDER CODE INFORMATION

Product	Supply	Certification
TPRA2M1-1-U	90-270V AC/DC	