



**FEATURES**

- 3 phase RMS current measurement with protection from Dry run, Over current, Lock current, Current Asymmetry, Phase Failure & Phase Sequence, Over Load (as per NEMA Curve)
- Selectable Power ON delay, Trip time delay & Recovery delay
- Earth fault protection
- 1 CO relay for trip
- Programmable 1 CO relay for alarm

**SPECIFICATIONS**

**HMI**

- 4 Digit Seven Segment Display
- 3 Keys For Control and Setting

**ELECTRICAL CONNECTION**

3Ø-3 wire

**AUXILIARY SUPPLY**

- 90V-270V AC/DC
- 50-60Hz
- 4VA max.

**CURRENT MEASURING RANGE**

- A) Motor rated current (IR) measuring with MPCT from 3A-80A.
- MPCT D15 10A
  - MPCT D15 40A
  - MPCT D15 80A
- B) Earth fault current measurement with EFCT From 1A-160A
- EFCT 100/25 160/1A VA1 CL 1
  - EFCT 140/35 160/1A VA1 CL 1

**TIME SETTINGS**

Power ON Delay : 1 - 999sec  
 Trip time delay : 0 - 999sec  
 (For OC, UC, LC, Asymmetry, Earth Fault)  
 Phase Failure : Instantaneous(<120ms)  
 Phase Reversal : Instantaneous(<400ms)  
 Reset Time : 1-999sec for current parameters  
 : 1-999 sec for Earth Fault  
 Response Time : <400ms  
 Reset Attempts : 3 (fixed)  
 Reset Attempt Time Frame : 0 - 999min

**HYSTERESIS**

Current : 0-99A

**RESOLUTION**

Current : 0.01 for < 10A  
 : 0.1 for >10A

**ACCURACY**

Time : ±5%+100msec  
 Current : 5% of IR(Rated Current)

**OUTPUT SPECIFICATIONS**

2 Relays : Relay1 : TRIP (1CO)  
 Relay2 : ALARM (1CO)

**RELAY RATING**

NO (5A, 250V AC/28VDC)  
 NC (5A, 250V AC/28VDC)

**LED INDICATION**

LED1 (Red) : Relay1  
 LED2 (Red) : Relay2  
 (Continuously ON after trip)

**RESET CONDITION**

- Power ON reset
- Terminal reset (Y1 & Y2 short)
- Press RST key for 3 sec.
- Auto reset (As per settings)

**TEST / RESET FUNCTION**

Test / Reset function is used to check proper functioning of product. It includes

- Relay contact switching
- LED Check
- Internal Circuit verification

**TEST MODE**

- To check Test mode press ▲ key for 3sec
- Y1 & Y2 short

**RESET MODE**

- To check Reset mode press ▼ Reset key for 3 sec.
- Y1 & Y2 short

**ENVIRONMENTAL SPECIFICATIONS**

- Indoor use  
 - Altitude of up to 2000 meters  
 - Pollution degree II  
 Temperature : Operating : 0 to 55°C  
 Storage : -20 to 70°C  
 Humidity : Up to 95% RH, non-condensing

**MECHANICAL SPECIFICATIONS**

Size : 96 x 96 mm  
 Mounting : Panel Mount  
 Wire Size (max) : 4 sq.mm  
 Screw tightening torque : 0.5 N-M

**WEIGHT** : 300gm approx.

**LED INDICATION CHART**

Various Conditions	'R1' LED	'R2' LED
No fault	OFF	OFF
Trip (Relay 1)	ON	OFF
Alarm (Relay 2)	OFF	BLINKING
Trip (If programmed for alarm relay)	ON	ON

**TRIP INDICATION CHART**

Trip indication	Trip parameters
t.UC	Under Current
t.OC	Over Current
t.LC	Locked Current
t.CA	Current Asymmetry
PHL	Phase Loss
PHS	Phase Sequence
t.OL	Over Load
EFR	Earth Fault

**ORDER CODE INFORMATION**

PRODUCT	SUPPLY	CERTIFICATION
MPR-341-2	230V AC	CE UL

**ACCESSORIES**

PRODUCT	SUPPLY	CERTIFICATION
MPCT D15 10A	10A	---
MPCT D15 40A	40A	---
MPCT D15 80A	80A	---

PRODUCT	CURRENT RATIO	CERTIFICATION
EFCT 100/25 160/1A VA1 CL 1	160/1A	---
EFCT 140/35 160/1A VA1 CL 1	160/1A	---

**TERMINAL CONNECTIONS**

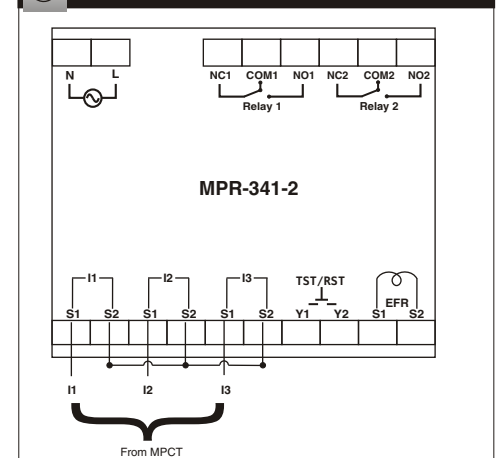

**WIRING DIAGRAM**

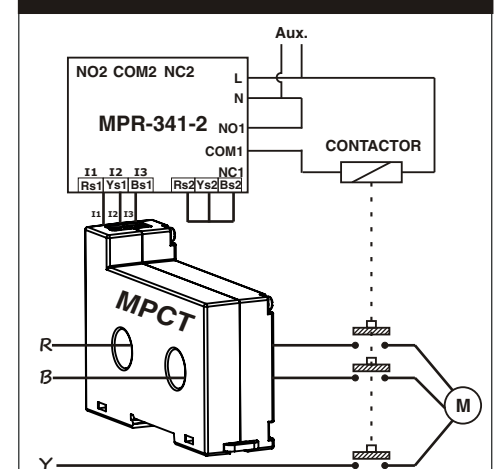

**NOTE** : Use of contactor recommended

**CONFIGURATION MENU**

Press ▲ + ▼ for 3sec. to enter or exit configuration menu

Network Selection (NWK) <span style="float: right;">Press ● + ▲ to enter sub menu from main menu</span>				
Press ▲ or ▼ to scroll through sub menu		Press ● + ▲ or ● + ▼ to change parameter value Press ● to set parameter value.		
DISPLAY (For 1sec)	DESCRIPTION	DEFAULT VALUE	RANGE	CONDITION
PON	Power ON Delay	1	1 to 999 sec	Relay status: Trip (connection as per mode selection)
CTSL	CT Selection	10	10A, 40A, 80A	MPCT Selection as per application & motor rating
rtdC	Rated Current	10	3A - 10A (Default : 10A) 11A - 40A (Default : 40A) 24A - 80A (Default : 80A)	Default value will be as per selected range
OL	Over Load	5	Class 5, 10, 15, 20, 30 (Starts with disable)	This parameter ensure tripping as per selected class
OC	Over Current	20	(Ir+1)A to 60A(Default :20A) (Ir+1)A to 240A(Default : 80A) (Ir+1)A to 480A(Default: 160A)	This parameter is only applicable when motor is started
OCt	Over Current Trip Time	1	0 to 999 sec	This parameter will not be displayed if over current is disabled
UC	Under Current	5	1A to (Ir-1)A 5A to (Ir-1)A 10A to (Ir-1)A	This parameter is only applicable when motor is started
UCt	Under Current Trip Time	1	0 to 999 sec	This parameter will not be displayed if under current is disabled
CA	Current Asymmetry	2	1A to (Ir-1)A	This parameter is only applicable when motor is started
CAt	Current Asymmetry Trip Time	1	0 to 999 sec	This parameter will not be displayed if current asymmetry is disabled
LOC	Locked Current	20	(Ir+1)A to 60A(Default :20A) (Ir+1)A to 240A(Default : 80A) (Ir+1)A to 480A(Default: 160A)	This parameter is only applicable when motor is started
LOCt	Locked Current Trip Time	1	0 to 999 sec	This parameter will not be displayed if lock current is disabled
CrRr	Current Reset Time	5	1 to 999 sec	This parameter indicates recovery time
EFr	Earth Fault	160	Trip : Disable then 1A to 160A	Earth fault protection

DISPLAY (For 1sec)		DEFAULT VALUE	RANGE	CONDITION
EFrt	Earth Fault Trip Time	1	0 to 999 sec	This parameter will not be displayed if earth fault is disabled
EFrs	Reset Time EFR	5	1 to 999 sec	This parameter will not be displayed if earth fault is disabled
PHL	Phase Loss	ENB	ENB/DIS	This parameter will enable / disable phase loss
PHS	Phase Sequence	ENB	ENB/DIS	This parameter will enable / disable phase sequence
HYSL	Hysteresis	1	0A to 99A	This parameter is only applicable for alarm condition
rAPd	Rapid Cycle Time	30	0 - 999 min	Fixed reset 3 times. user has to manually reset 4th time
rL42	Relay 2 Condition	TRP	Disable / Trip / Alarm	Relay 2 can be configured as disable, alarm, Relay1
rL4ā	Relay Mode	ON	ON / OFF	Relay can be operated in fail safe & shunt trip mode
ALā	Alarm	5	1%-25% <sup>(1)</sup>	This parameter indicates alarm condition
LACH	Latch	ON	ON / OFF	If this parameter on, user has to manually reset the unit
FCTd	Factory Default	NO	YES / NO	This parameter will, reset all the saved parameters to default

**Note-** Step size : 1A for all current trip parameters  
Step size : 1sec for all time parametres.

(1) For Under current : Alarm value= Trip value+Alarm% of trip value  
For Over/Lock current : Alarm value=Trip value-Alarm% of trip value.

(1)In Trip value setting & configuration menu, if no key pressed for 30 sec, then unit resumes online mode.  
(2)When zero current is detected in all 3 phases ,it will not be considered as Phase Loss.

<b>RESET</b>	Press ▼ key for 3sec. to reset manually
<b>CURRENT</b>	Press ● key to view current value in Manual mode
<b>TRIP VALUE</b>	Press ● key for 3sec. To display trip value(when trip page is displayed & press same key to go back to trip page)

**Note-**If rated current value is less than set under current/current asymmetry trip value then default under current/ current asymmetry value will be Ir-1 and if rated current value is greater than over current/lock current trip value then default over current/lock current will be Ir+1.

## SAFETY PRECAUTIONS

All safety related codifications, symbols and instructions that appear in this operating manual or on the equipment must be strictly followed to ensure the safety of the operating personnel as well as the instrument.

If the equipment is not used in a manner specified by the manufacturer it might impair the protection provided by the equipment.

If there is physical damage to the unit then do not use it.

Read complete instructions prior to installation and operation of the unit.

## WIRING GUIDELINES

### WARNING

1. To prevent the risk of electric shock power supply to the equipment must be kept OFF while doing the wiring arrangement.
2. Wiring shall be done strictly according to the terminal layout with shortest connections. Confirm that all connections are correct.

### CAUTION

1. To ensure the safe operation of unit, check the wiring and connections.

## DIMENSIONS

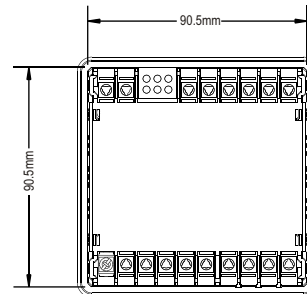
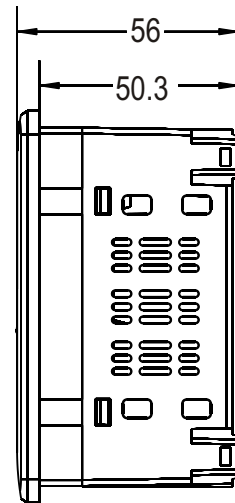
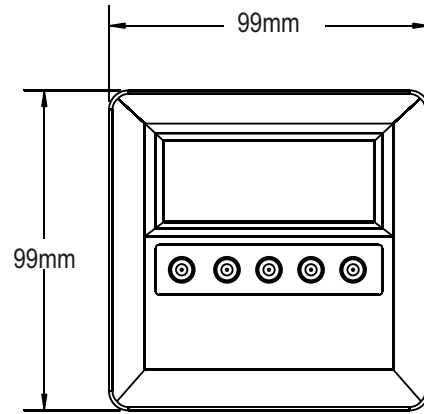

## CT DIMENSIONS

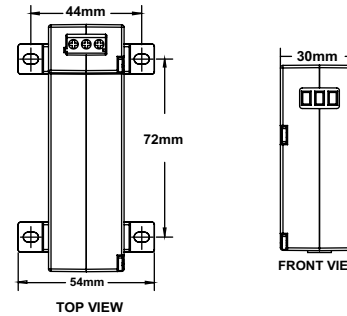
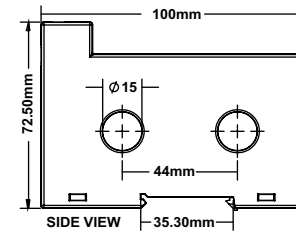

OUTLINE Dimensions (in mm)		PANEL CUTOUT Dimensions (in mm)
<p>Front View</p>	<p>Side View</p>	

## WARRANTY / LIMITATIONS OF LIABILITY

Selec warrants the products to be free from defects in the materials and workmanship for a period of one year (or other period specified, if any) from the date of sale by Selec.

The warranty does not apply to defects resulting from any action of the buyer, including but not limited to improper handling, operating the product outside the specification limits or unauthorized disassembling / altering of the product. The warranty shall be VOID if the product shows evidence of having been tampered or being damaged due to usage in corrosive environment; or current, heat, moisture or vibration; improper specification; wrong usage in an application; misuse or other operating conditions outside of Selec's control.

Selec shall not be responsible for special, indirect or consequential damages, loss of profits or commercial loss in any way connected with the products, whether such claim is based on contract, warranty, negligence or strict liability.

In no event shall the responsibility of Selec for any act exceed the individual price of the product on which liability is asserted.

In no event shall Selec be responsible for warranty or other claims regarding the products unless Selec's analysis confirms that the products were properly handled, stored, installed and maintained and not subject to contamination, abuse, misuse or inappropriate modification or repair.

( Specifications are subject to change, since development is a continuous process )

### Selec Controls Pvt. Ltd.

Tel. No. : +91-22-40394200 / 40394202

Fax No. : +91-22-28471733 | Toll free : 1800 227 353

Website: [www.selec.com](http://www.selec.com) | Email : [sales@selec.com](mailto:sales@selec.com)

Disclaimer : This product is strictly for industrial use and for sale in non European countries only