



96 x 48mm

### Features :

- ▶ 4+4 Digits, 7 Segment LED dual display
- ▶ Universal input
- ▶ ON - OFF/ PID control
- ▶ °C/°F selectable
- ▶ Heat cool PID
- ▶ Ramp soak
- ▶ Soft start
- ▶ RS485 Communication MODBUS RTU Protocol
- ▶ Retransmission analog output

## Technical specifications

Display specifications	
Display	4+4 digits 7 Segment LED dual display
Height of display	Upper display: 10 mm, Lower display: 7 mm
LED indication	1: Main output ; 2, 3: Alarm output ; M: Manual output ; T: Tune
Input specifications	
Inputs	Thermocouple (J, K, T, R, S, C, E, B, N, L, U, W, Platinel II), RTD (PT100), Signal inputs (- 5 to 56mV, 0 to 10V, 0 to 20mA)
Resolution	1/ 0.1 for TC/ RTD only (fixed 1° resolution for R & S type TC) Decimal point position selectable: 1/ 0.1/ 0.01/ 0.001 for analog input
Indication accuracy	For TC inputs: 0.25% of F.S. ±1° For R & S type TC inputs: 0.5% of F.S. ±2° (20 min of warm up time for TC inputs) For RTD input: 0.1% of F.S. ±1° For Analog input: ±0.5%, ±1° digit (F.S. = Full scale)
Temperature unit	°C/°F selectable
Input filter (FTC)	1 to 99 sec
Sampling time	200 ms
Output specifications	
<b>Control output</b> (Optional)	1
Contact rating (SPST)	5A @ 230 VAC/ 30 VDC, resistive
SSR drive (Voltage pulse)	12 VDC, 20 mA
Current	4 to 20mA DC (loop impedance: 500Ω max)
Voltage	0 to 10 VDC (load resistance: 10KΩ min)
<b>Auxiliary output</b> (Optional)	2
Contact rating (SPST)	5A @ 230 VAC/ 30 VDC
SSR drive	12 VDC, 20 mA
Functional specifications	
Control action	1) PID Control 2) ON-OFF control
Proportional band (P)	0.0 to 400.0°C
Integral time (I)	0 to 3600 sec
Derivative time (D)	0 to 200 sec
Cycle time	0.1 to 100.0 sec
Hysteresis width	0.1 to 99.9°
Manual reset value	- 99.9 to 19.9°
Heat-cool	
Control action	PID
Proportional band-cool	0.0 to 400.0°
Cycle time-cool	0.1 to 100 sec
Dead band	Programmable from set point low limit to set point high limit.

Settings for alarm output	
Modes	Deviation high/ low, Absolute high/ low, Band, Sensor break
Hysteresis	0.1 to 99.9°
Ramp rate	1 to 9999°/ hr
Soak time	0 to 1440 min
Soft start time	0 to 999 min
Auxiliary supply specifications	
Supply voltage	90 to 270 VAC/ DC (50/ 60Hz)
Power consumption	5 VA max @ 230 VAC
Environment specifications	
Temperature	Operating: 0°C to 50°C (32 to 122°F); Storage: 20°C to 75°C (- 4 to 167°F)
Humidity (non - condensing)	85% max. from 0 to 50°C
Mechanical specifications	
Mounting	Panel
Weight	250 gms

## Terminal connections

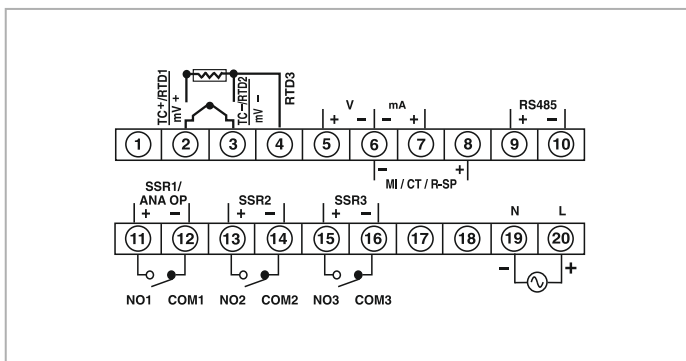

## Dimensions (All are in mm)

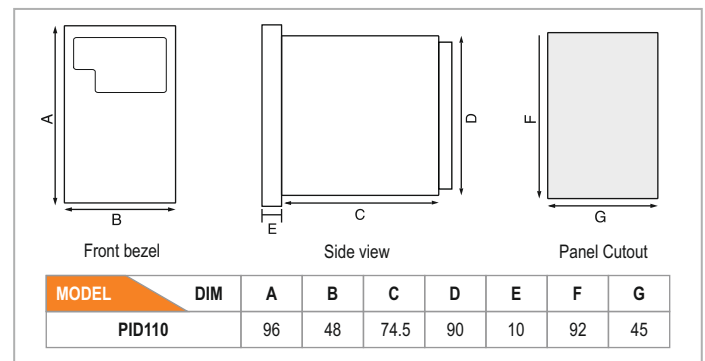

## Ordering information

Product code	Output 1	Output 2	Output 3	Comm. (RS485)	Supply voltage	Certification
PID110-2-0-04	4-20 mA	RELAY (5A)	RELAY (5A)	YES	90 to 270 VAC/ DC	---
PID110-0-0-01	RELAY (5A)	RELAY (5A)	RELAY (5A)	---	90 to 270 VAC/ DC	---