



DIN 35mm

Features :

- Monitors True RMS Earth Leakage Current (UPTO 30A) in 1Ø - 2 Wire, 3Ø - 3 Wire, 3Ø - 4 Wire systems
- Leakage Current (ΔI) & Time delay (Δt) adjustable
- LED Indication for Measured Leakage Current and various user settings
- Test and Reset function vai Front/Remote
- CBCT Open or Short Circuit Detection
- One SPDT Relay Output

Certifications :

Display Specification

Type	Analog
No. of LED	5
No. Of Knob	2
LED Indication	Power ON, Measured Leakage Current

Output Specification

1. Trip Relay : 1 SPDT	Case 1 : 10A @ 277V AC / 28 DC ⁽¹⁾ (NO) Case 2 : 5A @ 250V AC (NO) 5A @ 250V AC (NC)
Note : 1) Applicable when NC is not energized with load	

LED Indication Chart

Conditions	ON	25%	50%	75%	T
Power on	ON	OFF	OFF	OFF	OFF
Tripped Indication	ON	ON	ON	ON	ON
CBCT Error / Absent / CBCT Short	ON	Blink	Blink	Blink	Blink
25% Leakage Current	ON	ON	OFF	OFF	OFF
50% Leakage Current	ON	ON	ON	OFF	OFF
75% Leakage Current	ON	ON	ON	ON	OFF

Auxiliary Supply Specifications

Supply Voltage	230V AC ($\pm 15\%$), 50/60Hz
Power Consumption	5VA max

Environmental Specification

Temperature	Operating : 0 to 50°C Storage : 0 to 75°C
Humidity(non-condensing)	Upto 95% RH
Pollution Degree	
For PCB	2
For Product	3
Degree of Protection of Device	IP20

Input Specifications

Monitored Leakage Current	30mA, 100mA, 300mA, 500mA and 1A, 3A, 5A, 10A, 20A, 30A
Trip Level Limits	95% to 105% of set leakage current value
Time Delay	0, 0.15, 0.25, 0.5, 1, 2, 3, 5, 7.5, 9 sec $\Delta t=0$ (When leakage set to 30mA)
Reset Time	~1 sec
CBCT Dectection	Yes, when CBCT Absent or short
Responce Time	< 30ms (If trip current $\geq 5X$ set value) < 50ms (if trip current = 1X set value)
Accuracy	Current : $\pm 5\%$ of Set Trip Current Time : $\pm 5\%$ of set Time + Response Time
Test / Reset Facility	1. Front (Key) 2. Remote (Through terminal contact) 3. Power interruption
Reset Enable Level	Below 85% of tripped level in presence of CBCT

Mechanical Specifications

Mounting	Din Rail
Weight	157gms

Dimensions

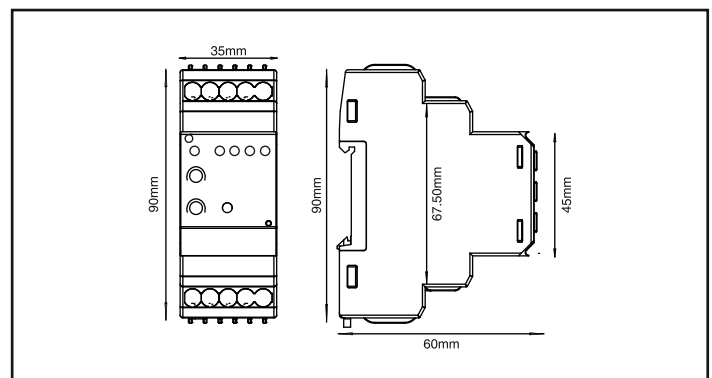

Terminal Connections

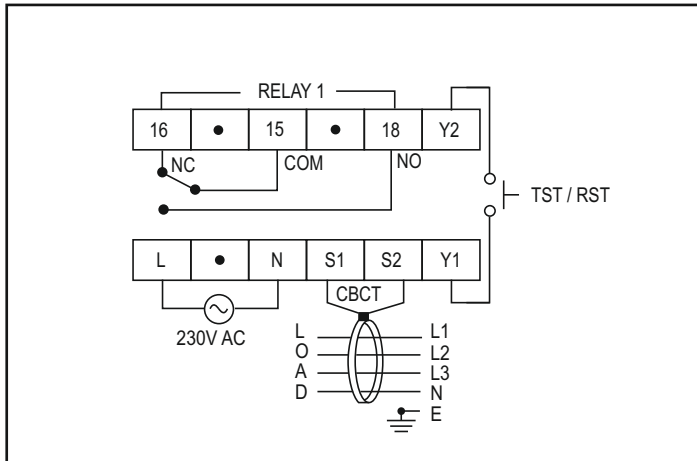

Ordering Information

Product Code	Supply Voltage	Certification
ELRA2M2-1-230V-CE	230V AC (±15%)	CE

Accessories

Product Code	Inner Diametes	Turns Ratio
CBCT-35-1	35mm Inner Diameter	1000:1
CBCT-70-1	70mm Inner Diameter	1000:1
CBCT-120-1	120mm Inner Diameter	1000:1
CBCT-210-1	210mm Inner Diameter	1000:1
CBCT-310-1	310mm Inner Diameter	1000:1

Compliance

Applicable EMI / EMC Standards		
Product Standard : IEC 60947-2		
Category	Reference Standards	Testing Level
Conducted Emissions	CISPR-11	Class-A
Conducted Susceptibility	IEC 61000-4-6	Class-A
Electrical Fast Transient	IEC 61000-4-4	Class-A
Electrostatic Discharge	IEC 61000-4-2	Class-A
Radiated Emission	IEC 61000-4-20	Class-A
Radiated Susceptibility	IEC 61000-4-3	Class-A
Surge	IEC 61000-4-5	Class-B
AC Voltage Test	IEC 61010-1	Clause 6.7
Resistance To Heat Test	IEC 61010-1	Clause 10.5
Single Fault Test	IEC 61010-1	Clause 4.4 and 10
Temperature Rise Test	IEC 61010-1	Clause 10.1 - 10.4