

SELEC

MFM391/MFM391-CE

Operating Instructions

OP868-V01



96 x 96

SPECIFICATIONS

DISPLAY

3 Row of 3 Digits
7 Segment LED Display Size 36.5 x 48 mm
Integrated with parameter Units

WIRING INPUT

3 Ø - 4 wire, 3 Ø - 3 wire

RATED INPUT VOLTAGE

11 to 300VAC (L-N); 19 to 519VAC (L-L)

FREQUENCY RANGE

50/60 Hz

RATED INPUT CURRENT

Nominal 5A (Min-20mA, Max-6A)

CT PRIMARY

1A/5A to 10,000A (Programmable for any value)

Note : 1A to 10,000A if CT secondary is 1 else 5A to 10,000A

CT SECONDARY

1A or 5A (programmable)

PT PRIMARY

100V to 500kV (Programmable for any value)

PT SECONDARY

100 to 500V (Programmable for any value)

DISPLAY UPDATE TIME

1 sec. for all parameters

DISPLAY SCROLLING

Auto / Manual

POWER CONSUMPTION

Less than 8VA

ENVIRONMENTAL CONDITIONS

- Indoor use
- Altitude of up to 2000 meters
- Pollution degree II
- Installation Category III

Temperature : Operating : -10°C to 55°C

Storage : -20°C to 75°C

Humidity : Up to 85% non-condensing

RPM : Pole : 0 (Range : 0-98, Selectable in step 2), Frequency : 45-65Hz

Run Hour : 0-99999.9hr

BURDEN : 0.5VA@5A per phase

MOUNTING : Panel mounting

WEIGHT

MFM391 : 190gms

MFM391-CE : 193gms

ORDER CODE INFORMATION

Product	Supply Voltage	Certification	
		CE	UL US LISTED
MFM391	85V - 270V AC, 50/60Hz	—	—
MFM391-CE	85V - 270V AC, 50/60Hz	■	—

ACCURACY

Measurement	Accuracy
Voltage V_{L-N}	±0.5% of F.S. ±2 digit
Voltage V_{L-L}	±0.5% of F.S. ±2 digit
Current	±0.5% of F.S. ±2 digit
Frequency	±0.1Hz ±1digit
Run Hour	±1%
RPM	±0.5%
Active Power	1%
Apparent power	1%
Reactive Power	1%
Power Factor	±0.01

Parameters	Description	Unit
Voltage (True RMS)	All phase to phase, phase to neutral and average	V, kV
Current (True RMS)	All phases and average	A, kA
Frequency	Frequency of present phase	Hz
Power Factor	All phases and average	PF
Active Power	All phases and Total	k,M
Reactive Power	All phases and Total	k,M
Apparent Power	All phases and Total	k,M
Run Hour	The time for which meter is on	—
RPM	RPM calculated from system frequency	—

SAFETY PRECAUTIONS

All safety related codifications, symbols and instructions that appear in this operating manual or on the equipment must be strictly followed to ensure the safety of the operating personnel as well as the instrument.

If the equipment is not used in a manner specified by the manufacturer it might impair the protection provided by the equipment.

- Do not use the equipment if there is any mechanical damage.
- Ensure that the equipment is supplied with correct voltage.

CAUTION :

1. Read complete instructions prior to installation and operation of the unit.
2. Risk of electric shock.
3. The equipment in its installed state must not come in close proximity to any heating sources, oils, steam, caustic vapors or other unwanted process by products.

WIRING GUIDELINES

WARNING :

1. To prevent the risk of electric shock, power supply to the equipment must be kept OFF while doing the wiring arrangement.
2. Wiring shall be done strictly according to the terminal layout. Confirm that all connections are correct.
3. Use lugged terminals.
4. To reduce electromagnetic interference use of wires with adequate ratings and twists of the same in equal size shall be made with shortest connections.
5. Layout of connecting cables shall be away from any internal EMI source.
6. Cable used for connection to power source, must have a cross section of 0.5mm² to 2.5mm² (20 to 14AWG ; 75°C(min)). These wires shall have current carrying capacity of 6A.
7. Copper cable should be used (Stranded or Single core cable).
8. Before attempting work on device, ensure absence of voltages using appropriate voltage detection device.

INSTALLATION GUIDELINES

CAUTION :

1. This equipment, being built-in-type, normally becomes a part of main control panel and in such case the terminals do not remain accessible to the end user after installation and internal wiring.
2. Conductors must not come in contact with the internal circuitry of the equipment or else it may lead to a safety hazard that may in turn endanger life or cause electrical shock to the operator.
3. Circuit breaker or mains switch must be installed between power source and supply terminals to facilitate power 'ON' or 'OFF' function. However this switch or breaker must be installed in a convenient position normally accessible to the operator.
4. Before disconnecting the secondary of the external current transformer from the equipment, make sure that the current transformer is short circuited to avoid risk of electrical shock and injury.
5. The equipment shall not be installed in environmental conditions other than those mentioned in this manual.
6. The equipment does not have a built-in-type fuse. Installation of external fuse of rating 275V AC / 0.5Amp for electrical circuitry / battery is highly recommended.

Config page.	Function	Range or Selection	Factory Setting
1	Network Selection	3P4W / 3P3W	3P4W
2	CT Secondary	1A or 5A	5
3	CT Primary	5A to 10,000A if CT Secondary is 5A 1A to 10,000A if CT Secondary is 1A	005
4	PT primary	100V to 500kV	350
5	PT Secondary	100V to 500V	350
6	No. of poles	0 to 98 (Selectable in step 2)	02
7	Reset Run Hour	Yes/No	No

MECHANICAL INSTALLATION

For installing the meter

1. Prepare the panel cutout with proper dimensions as shown below.
2. Push the meter into the panel cutout. Secure the meter in its place by fitting the clamp on the rear side. fit clamps on both sides in diagonally opposite location for optimum fitting.
3. For proper sealing, tighten the screws evenly with required torque. Terminal screw tightening torque : 0.5N.m 4.4Lb.in

Outline Dimensions (in mm)		Panel cutout Dimensions (in mm)

MAINTENANCE

1. The equipment should be cleaned regularly to avoid blockage of ventilating parts.
2. Clean the equipment with a clean dry or damp cloth. Do not use any cleaning agent other than water.

TERMINAL CONNECTIONS

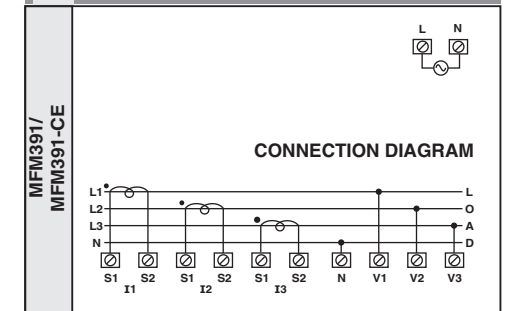

FRONT PANEL DESCRIPTION

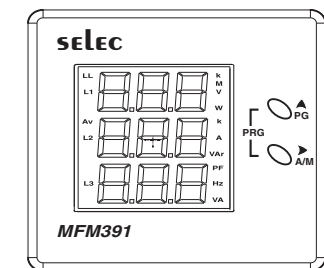

ONLINE PAGE DESCRIPTION

There are two dedicated keys labelled as ▲ and ►. Use these 2 keys to read parameters. Simply press these keys to read the parameters. Units of corresponding parameters on display will glow automatically.

- 1) Key 1 (▲/PG) : To Increment Main Page.
- 2) Key 2 (►/A/M) : To Increment subpages of respective Main Page

For 3P4W		
KEY PRESS	ONLINE PAGE DESCRIPTION	
Press "▲"	1st screen	Displays three phase line to neutral voltage.
Press "▶"	2nd screen	Displays three phase line to line voltage.
Press "▲"	1st screen	Displays three phase line to neutral current.
Press "▶"	2nd screen	Displays RPM.
Press "▶"	3rd screen	Displays Run Hour.
Press "▲"	1st screen	Displays three phase average line to neutral voltage, current and power factor.
Press "▶"	2nd screen	Displays three phase average line to line voltage, current and frequency.
Press "▶"	3rd screen	Displays first phase line to neutral voltage , current and power factor.
Press "▶"	4th screen	Displays second phase line to neutral voltage , current and power factor.
Press "▶"	5th screen	Displays third phase line to neutral voltage , current and power factor.
Press "▲"	1st screen	Displays three phase total active power, reactive power and apparent power.
Press "▶"	2nd screen	Displays first phase active power, reactive power and apparent power.
Press "▶"	3rd screen	Displays second phase active power, reactive power and apparent power.
Press "▶"	4th screen	Displays third phase active power, reactive power and apparent power.

For 3P3W		
KEY PRESS	ONLINE PAGE DESCRIPTION	
Press "▲"	1st screen	Display three phase line to line voltage.
Press "▲"	1st screen	Displays three phase line to line current.
Press "▶"	2nd screen	Displays RPM.
Press "▶"	3rd screen	Displays Run Hour.
Press "▲"	1st screen	Displays three phase average line to line voltage, current and frequency.

For 3P3W		
KEY PRESS	ONLINE PAGE DESCRIPTION	
Press "▶"	2nd screen	Displays first phase line to line voltage , current and three phase average power factor.
Press "▶"	3rd screen	Displays second phase line to line voltage , current and three phase average power factor.
Press "▶"	4th screen	Displays third phase line to line voltage , current and three phase average power factor.
Press "▲"	1st screen	Displays three phase total active power, reactive power, apparent power.

SERIAL NUMBER DESCRIPTION

Press ▲ key for 10 sec to display serial number..

AUTOMATIC / MANUAL / DEFAULT MODE

Press ▶ key for 5 sec to toggle between **AUTOMATIC / MANUAL** .

CONFIGURATION

For the configuration setting mode :

- Use ▲ + ▶ key for 3 sec to enter and exit from configuration menu.
- Use ▲ key to increment the configuration pages .
- Use ▶ key to edit the value and shift the cursor for next digit to edit.
- Use ▶ key for 2 sec save the parameter value .
- Press ▲ key for next page.

Press first Key▲ for 2 second to set CT/PT primary values in Kilo from normal and vice versa.

Eg:- If user want to set 1300 = first set digit 001 then hold key▲ for 2 sec to shift in k, then display will show 1.00k ,press ▶ shift the cursor for next digit. next press▲ key to change values after the decimal point 1.3k and than hold ▶ key for 2 sec to save the parameters , it will show 1.30k.

TYPICAL WIRING DIAGRAM

3 Phase - 4 Wire (Commonly Used)

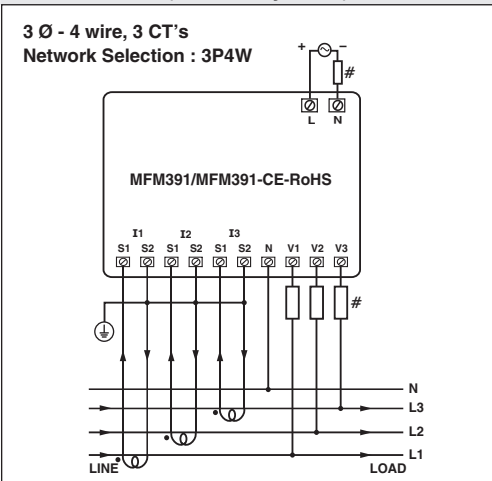

TYPICAL WIRING DIAGRAM

#All fuse types : 0.5A class CC UL type ; 0.5A fast acting 600V

3 Phase - 4 Wire

3 Ø - 4 wire, 3 CT's and 3 PT's
Network Selection : 3P4W

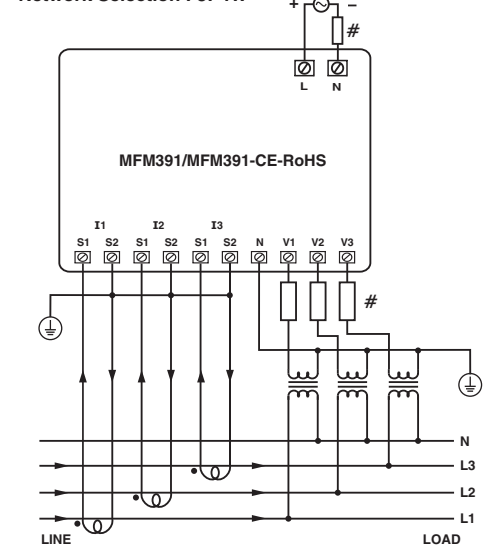

3 Phase - 3 Wire

3 Ø - 3 wire, 2 CT's and 2 PT's
Network Selection : 3P3W

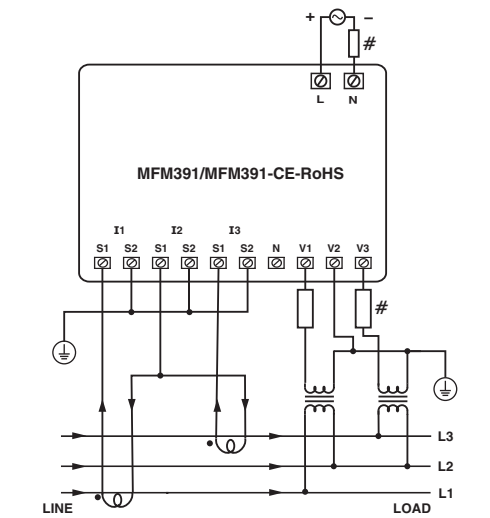

Note : + and - is applicable only for DC Product.

2 Phase - 3 Wire

2 Ø - 3 wire, 2 CT's 2 PT's
Network Selection : 3P4W

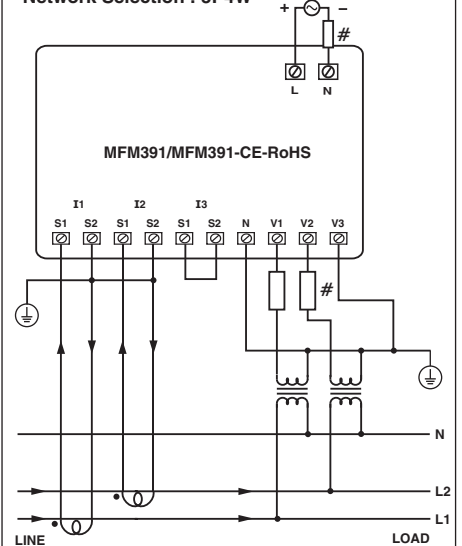

1 Phase - 2 Wire

1 Ø - 2 wire, 1 CT
Network Selection : 3P4W

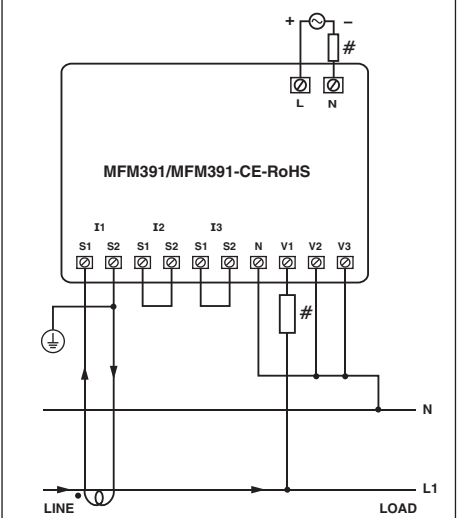

(Specifications subject to change as development is a continuous process.)

Selec Controls Pvt. Ltd., India

Factory Address :

EL-27/1, Electronic Zone, TTC Industrial Area,
MIDC, Mahape, Navi Mumbai - 400 710, INDIA.

Tel. No. : +91-22-41418468 / 52

Fax No. : +91-22-28471733 | Toll free : 1800 227 353

Website: www.selec.com | Email: sales@selec.com