

selec**EM368 / EM368-C**

Operating Instructions



96 x 96

FEATURES

- 8 digit LCD with backlight display
- User programmable CT primary, CT Secondary, PT primary and PT Secondary
- User programmable network selection
- Memory retention
- Password protected energy reset
- Potential free Pulse output for energy
- 100 to 240V AC auxiliary supply
- RS485 communication (MODBUS Protocol)

SPECIFICATIONS**DISPLAY**

8 digit LCD display, Height 10.5mm

LCD INDICATIONS**INT** - Integration of energy**X10** - Resolution is 10**REV** - Reverse connected CT or Voltage wiring

- Communication in progress

- Pulse output

WIRING INPUT

3 Ø - 4 wire, 3 Ø - 3 wire, 2 Ø - 3 wire and

1 Ø - 2 wire system

RATED INPUT VOLTAGE

11 to 300V AC (L-N);

19 to 519V AC (L-L); Installation Category III (600V)

UL Approval :

11 to 277V AC (L-N);

19 to 480V AC (L-L); Installation Category III (600V)

FREQUENCY RANGE

45-65Hz

RATED INPUT CURRENT

Nominal 5A (Min-11mA, Max-6A)

CT PRIMARY

1A / 5A to 10,000A (Programmable for any Value)

Note : 1A to 10,000A if CT secondary is 1 else CT primary is 5A to 10,000A**CT SECONDARY**

1A or 5A (programmable)

PT PRIMARY

100V to 500kV (Programmable for any value)

PT SECONDARY

100 to 500V AC (L-L) (Programmable for any value)

BURDEN

0.5 VA@5A per phase

MEASUREMENT

Total active Energy (kWh)

Total reactive Energy (kVAh)

Total apparent Energy (kVAh)

Total active power (kW)

Total reactive power (kVAh)

Power factor (Individual and Average)

Note : All energies are resettable**MEASUREMENT RANGE**

99999999

POWER CONSUMPTION

Less than 8VA

ENVIRONMENTAL CONDITIONS

- Indoor use
- Altitude of up to 2000 meters
- Pollution degree II

Temperature : Operating : -10°C to 55°C

Storage : -20°C to 75°C

Humidity : Up to 85% non-condensing

PROTECTION CLASS : II**MOUNTING :** Panel mounting**WEIGHT**

EM368 : 302gms

EM368-C : 312gms

OUTPUT**Pulse Output :** Voltage range : 24V DC max.

Current capacity : 100mA max.

Pulse Width : 100ms ± 5ms.

ORDER CODE INFORMATION			
PRODUCT	SUPPLY	CERTIFICATION	
		CE	cULus LISTED
EM368 / EM368-C	100 to 240V AC, -15% +12%, 50 / 60Hz, (±5%)	—	—
EM368-CE / EM368-C-CE	100 to 240V AC, -15% +12%, 50 / 60Hz, (±5%)	■	—
EM368-CU / EM368-C-CU	100 to 240V AC, -15% +12%, 50 / 60Hz, (±5%)	■	■

Installation Category III

ACCURACY	
Measurement	Accuracy
Active Power	±1%
Reactive Power	±1%
Power factor	±1%
Average Power factor	±1%
Active energy	Class 1
Reactive energy	±1%
Apparent energy	±1%

RESOLUTION		
PT Ratio x CT Ratio	kWh	Pulse
<15	0.01K	0.01K
<150	0.1K	0.1K
<1500	1K	1K
<15000	0.01M	0.01M
<150000	0.1M	0.1M
<1500000	1M	1M
≥1500000	10M	10M

NOTE :

- 1) For power, resolution is automatically adjusted
- 2) For power factor, resolution is 0.01
- 3) INT blinks after every 5 seconds, if load on any one of three phase is present.

SAFETY PRECAUTIONS

All safety related codifications, symbols and instructions that appear in this operating manual or on the equipment must be strictly followed to ensure the safety of the operating personnel as well as the instrument.

If the equipment is not used in a manner specified by the manufacturer it might impair the protection provided by the equipment.

- Do not use the equipment if there is any mechanical damage.
- Ensure that the equipment is supplied with correct voltage.

CAUTION :

1. Read complete instructions prior to installation and operation of the unit.
2. Risk of electric shock.
3. The equipment in its installed state must not come in close proximity to any heating sources, oils, steam, caustic vapors or other unwanted process by products.

WIRING GUIDELINES**WARNING :**

1. To prevent the risk of electric shock, power supply to the equipment must be kept OFF while doing the wiring arrangement.
2. Wiring shall be done strictly according to the terminal layout. Confirm that all connections are correct.
3. Use lugged terminals.
4. To reduce electromagnetic interference use of wires with adequate ratings and twists of the same in equal size shall be made with shortest connections.
5. Layout of connecting cables shall be away from any internal EMI source.
6. Cable used for connection to power source, must have a cross section of 0.5mm² to 2.5mm² (20 to 14AWG ; 75°C (min)). These wires shall have current carrying capacity of 6A.
7. Copper cable should be used (Stranded or Single core cable).
8. Before attempting work on device, ensure absence of voltages using appropriate voltage detection device.

INSTALLATION GUIDELINES**CAUTION :**

1. This equipment, being built-in-type, normally becomes a part of main control panel and in such case the terminals do not remain accessible to the end user after installation and internal wiring.
2. Conductors must not come in contact with the internal circuitry of the equipment or else it may lead to a safety hazard that may in turn endanger life or cause electrical shock to the operator.
3. Circuit breaker or mains switch must be installed between power source and supply terminals to facilitate power 'ON' or 'OFF' function. However this switch or breaker must be installed in a convenient position normally accessible to the operator.
4. Before disconnecting the secondary of the external current transformer from the equipment, make sure that the current transformer is short circuited to avoid risk of electrical shock and injury.
5. The equipment shall not be installed in environmental conditions other than those mentioned in this manual.
6. The equipment does not have a built-in-type fuse. Installation of external fuse of rating 275V AC / 0.5Amp for electrical circuitry / battery is highly recommended.

MECHANICAL INSTALLATION

For installing the meter

1. Prepare the panel cutout with proper dimensions as shown below.
2. Push the meter into the panel cutout. Secure the meter in its place by fitting the clamp on the rear side. Fit clamps on both sides in diagonally opposite location for optimum fitting.
3. For proper sealing, tighten the screws evenly with required torque.
Terminal screw tightening torque :
0.68 N-m to 0.79 N-m (6.018 In-Lb to 6.992 In-Lb)
Screw clamp tightening torque : 0.1N-m (0.885 Lb-inch)

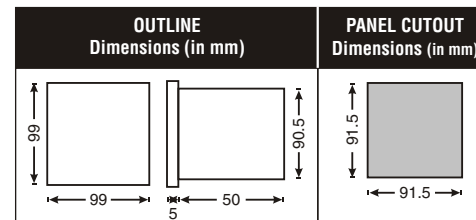
**MAINTENANCE**

1. The equipment should be cleaned regularly to avoid blockage of ventilating parts.
2. Clean the equipment with a clean dry or damp cloth. Do not use any cleaning agent other than water.

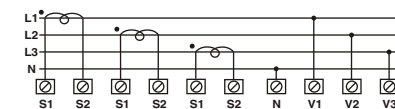
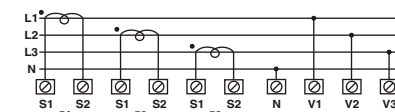
TERMINAL CONNECTIONS**EM368 (-CE/CU)****CONNECTIONS DIAGRAM****EM368-C (-CE/CU)****CONNECTIONS DIAGRAM**

FRONT PANEL DESCRIPTION

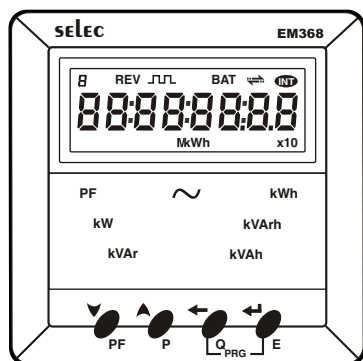

Keys Description (Online pages)

Sr. No.	Keys	Function
1	PF (▼)	To view individual and average power factor
2	P (▲)	To view total active power
3	Q (←)	To view total reactive power
4	E (↵)	To view total reactive and apparent energy

NOTE :

By default total active energy (kWh) will be displayed all the time and at momentary key press unit shall display the corresponding page for 5sec.

Keys Description (Configuration)

Sr. No.	Functions	Key press
1	To enter into configuration mode.	↵ and ↵ for 3sec.
2	To scroll through the pages in forward direction in configuration mode.	↵ go to next page
3	To scroll through the pages in reverse direction in configuration mode.	← go to previous page
4	To increase and decrease all parameter values	▲ Increase ▼ Decrease

CONFIGURATION SCHEME (parameter setting)

To enter configuration : Press ↵ and ↵ for 3sec.

Key press	Display	Description
01. Password Factory setting : 10		
Display	PASSWORD	
Press ▼/▲	10	Range : 0 to 9998
Press ↵ key		for next parameter

02. Change password

Factory setting : No

Display **CHANGE PASSWORD**
 Press ▼/▲ **NO** Range : No / Yes
 Press ↵ key for next parameter
Note : If 'NO' then after pressing ↵ key, menu will go to network selection

03. New password

Factory setting : 0

Display **NEW PASSWORD**
 Press ▼/▲ **0** Range : 0 to 9998
 Press ↵ for next parameter
 Press ← for previous parameter

04. Network selection

Factory setting : 3P-4W

Display **NETWORK SELECT**
 Press ▼/▲ **3P-4W** Range : 3 Ø - 4 W
 3 Ø - 3 W
 Press ↵ for next parameter
Note : For 2 Ø 3 wire, 1 Ø 2 wire select 3 Ø 4 wire network

05. CT secondary

Factory setting : 5

Display **CT SECONDARY**
 Press ▼/▲ **5** Range : 1A or 5A
 Press ↵ for next parameter
 Press ← for previous parameter

06. CT primary

Factory setting : 5

Display **CT PRIMARY**
 Press ▼/▲ **5** Range : 5 to 10,000A OR 1 to 10,000A
 Press ↵ for next parameter
 Press ← for previous parameter
Note : 1 to 10,000A if CT secondary is 1 else CT primary is 5 to 10,000A

07. PT secondary

Factory setting : 350

Display **PT SECONDARY**
 Press ▼/▲ **350** Range : 100 to 500V AC (L-L)
 Press ↵ for next parameter
 Press ← for previous parameter

08. PT primary

Factory setting : 350

Display **PT PRIMARY**
 Press ▼/▲ **350** Range : 100V to 500kV
 Press ↵ for next parameters
 Press ← for previous parameter

09. Slave ID

Factory setting : 1

Display **SLAVE ID**
 Press ▼/▲ **1** Range : 1 to 255
 Press ↵ for next parameter
 Press ← for previous parameter
(Optional, available in EM368-C)

10. Baud rate

Factory setting : 9600

Display **BAUD RATE**
 Press ▼/▲ **9600** Range : 300, 600, 1200, 2400, 4800, 9600 and 19200
 Press ↵ for next parameter
 Press ← for previous parameter
(Optional, available in EM368-C)

11. Parity

Factory setting : None

Display **PARITY**
 Press ▼/▲ **NONE** Range : Even, Odd, None
 Press ↵ for next parameter
 Press ← for previous parameter
(Optional, available in EM368-C)

12. Stop bit

Factory setting : 1

Display **STOP BIT**
 Press ▼/▲ **1** Range : 1 / 2
 Press ↵ for next parameter
 Press ← for previous parameter
(Optional, available in EM368-C)

13. Reset energy

Factory setting : No

Display **RESET ENERGY**
 Press ▼/▲ **NO** Range : No / Yes
 Press ↵ for next parameter
 Press ← for previous parameter
Note : If 'NO' then after pressing ↵ key, menu will go to Network selection

14. Password

Factory setting : 11

Display **PASSWORD**
 Press ▼/▲ **11** Range : 1 to 9999
 Press ↵ for next parameter
 Press ← for previous parameter
Note : Password is : configuration password +1

15. Reset Active Energy

Factory setting : No

Display **RESET ACTIVE ENERGY**
 Press ▼/▲ **NO** Range : No / Yes
 Press ↵ for next parameter
 Press ← for previous parameter
Note : User should note the reading before resetting

16. Reset Apparent Energy

Factory setting : No

Display **RESET APPARENT ENERGY**
 Press ▼/▲ **NO** Range : No / Yes
 Press ↵ for next parameter
 Press ← for previous parameter
Note : User should note the reading before resetting

17. Reset Reactive Energy

Factory setting : No

Display **RESET REACTIVE ENERGY**
 Press ▼/▲ **NO** Range : No / Yes
 Press ↵ for next parameter
 Press ← for previous parameter
Note : User should note the reading before resetting

18. Default value

Factory setting : No

Display **DEFAULT VALUE**
 Press ▼/▲ **NO** Range : No / Yes
 Press ↵ for next parameter
 Press ← for previous parameter
Note : On pressing ↵ key, configuration will go to network selection page.
 If 'yes' selected unit will be formatted to factory setting

SERIAL NUMBER DESCRIPTION

Press P (▲) key for 10sec. to display 8 digit serial number only for 5sec.

Exit configuration mode:



- Press ↵ and ↵ key for 3 sec in configuration mode.
- Do not press any key for 30 sec in configuration mode.
- Power OFF and power ON the unit again.



NOTE :

- 1) Pressing ↵ key will save the value of the current parameter and move on to next parameter.
- 2) Continuous operating of ▼ or ▲ key makes parameter value update speed faster in 3 stages after 7 sec.
- 3) In configuration menu repeated pressing of ↵ key will allow toggling between all the configuration parameters.



USER GUIDE

What does the INT, X10, REV,  and  on the LCD display indicate?

- INT : The INT on the LCD provides quick visual indication of energy integration. INT indication keeps blinking once in 5 sec, for presence of voltage and current in any of the three phases.
- X10 : X10 on the LCD is ON when the resolution is 10. It is the indication of count reading which must be multiplied by 10 to get actual kWh / kVAh / kVAh consumed.
- REV : REV on the LCD gives the indication of reversal of one or more CT connections / Phase. In such cases meter may not indicate the correct energy consumption. The CT should be connected to the meter with correct polarities.
-  This symbol on the LCD shows that the communication is in progress.
-  This symbol on the LCD indicates that a pulse is output.

NETWORK SELECTION AND WIRING INPUT

Network selection in configuration mode	Wiring
3P4W	3P4W, 2P3W, 1P2W
3P3W	3P3W

APPLICATION OF PULSE OUTPUT

● PROCESS INTEGRATION

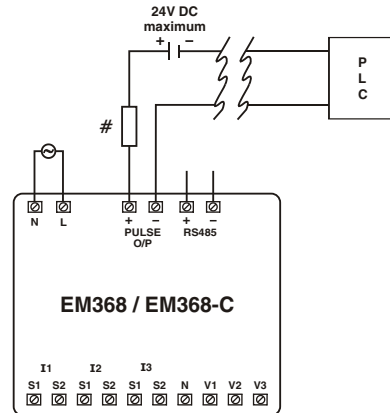

Pulse output from EM368 meter can be interfaced into a process through a PLC for on line control of energy content in the process.
If the PLC has a self excited digital input, external DC supply is not needed.
The kWh pulse is also used to derive average kWh information at the PLC.

● ENERGY CONTROLLER

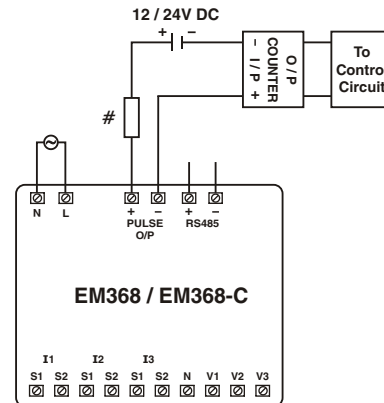

Pulse output from EM368 meter can be used as alarm generator or total energy controller by interfacing it with Pre-settable counter and control circuits (Contactors, Relay, Trip Circuit).

The counter is loaded with the maximum energy consumption. When count reaches setpoint it provides output to control circuit to take appropriate action.

All fuse types : 0.5A class CC UL type
0.5A fast acting 600V

MODBUS register addresses list

Readable parameters from EM368-C

Address	Hex Address	Parameter	Length (Register)	Data Structure
30000	0x00	Active Energy	2	Float
30002	0x02	Apparent Energy	2	Float
30004	0x04	Reactive Energy	2	Float
30006	0x06	Power Factor Phase 1	2	Float
30008	0x08	Power Factor Phase 2	2	Float
30010	0x0A	Power Factor Phase 3	2	Float
30012	0x0C	Average Power factor	2	Float
30014	0x0E	Total kW	2	Float
30016	0x10	Total kVAh	2	Float

Readable / Writable parameters from EM368-C

Address	Hex Address	Parameter	Range		Length (Register)	Data Structure
			Min value	Max value		
40000	0x00	New Password	1	9998	1	Integer
40001	0x01	N/W selection	Value	Meaning		
			0	3P-4W	1	Integer
			1	3P-3W		
40002	0x02	CT Secondary	Write Value	CT Secondary	1	Integer
			1	1A		
			5	5A		
40003	0x03	CT primary	5A (CT Sec = 5A)	10000A	1	Integer
40003	0x03	CT primary	1A (CT Sec = 1A)	10000A	1	Integer
40004	0x04	PT Secondary	100V	500V	1	Integer
40005	0x05	PT primary	100V	500kV	2	Integer
40008	0x08	Slave Id	1	255	1	Integer
40009	0x09	Baud rate	Value	Baud rate (bps)		
			0x0000	300	1	Integer
			0x0001	600		
			0x0002	1200		
			0x0003	2400		
			0x0004	4800		
			0x0005	9600		
			0x0006	19200		
40010	0x0A	Parity	Value	Parity		
			0x0000	None	1	Integer
			0x0001	Odd		
			0x0002	Even		
40011	0x0B	Stop bits	Value	Stop bit	1	Integer
			0x0000	1		
			0x0001	2		
			Value	Meaning		
40012	0x0C	Reset kWh	1	Reset Active Energy	1	Integer
40013	0x0D	Reset kVAh	1	Reset Apparent Energy	1	Integer
40014	0x0E	Reset kVAh	1	Reset Reactive Energy	1	Integer

TYPICAL WIRING DIAGRAM

3 PHASE 4-WIRE (COMMONLY USED)

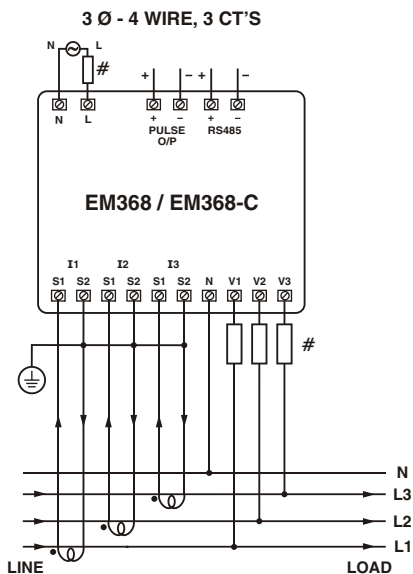

3 PHASE 3-WIRE

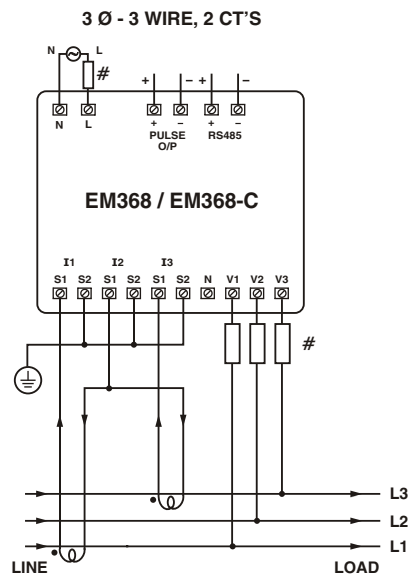

2 PHASE - 3 WIRE

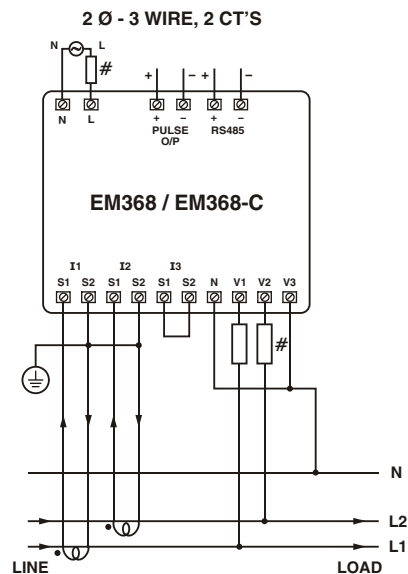

1 PHASE - 2 WIRE

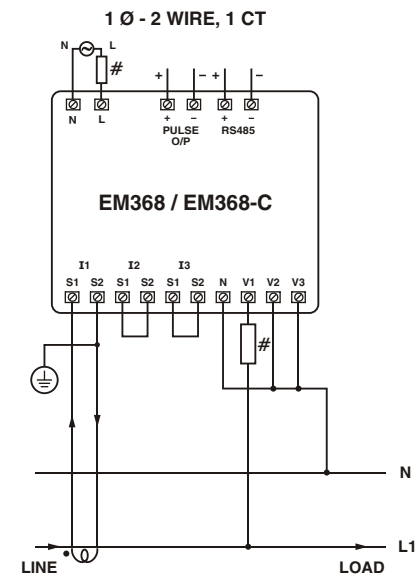

3 Ø - 4 WIRE, 3 CT'S and 3 PT'S

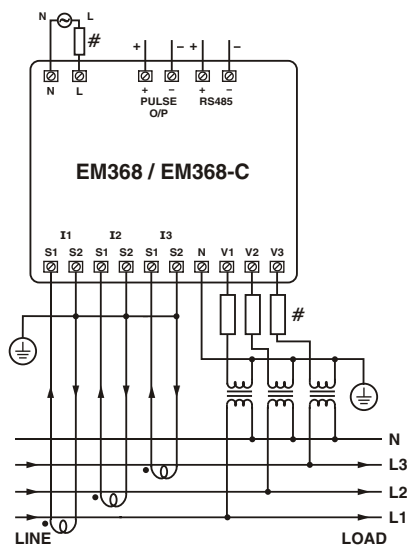

3 Ø - 3 WIRE, 2 CT'S and 2 PT'S

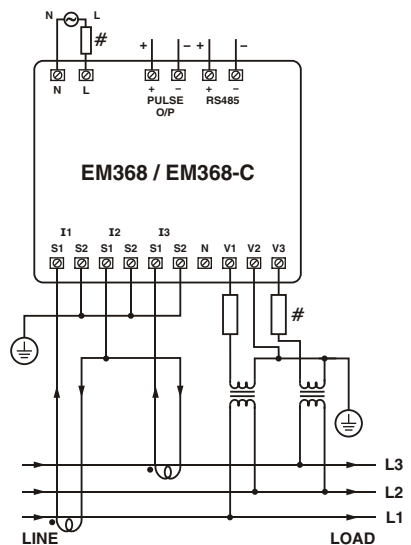

2 Ø - 3 WIRE, 2 CT'S and 2 PT'S

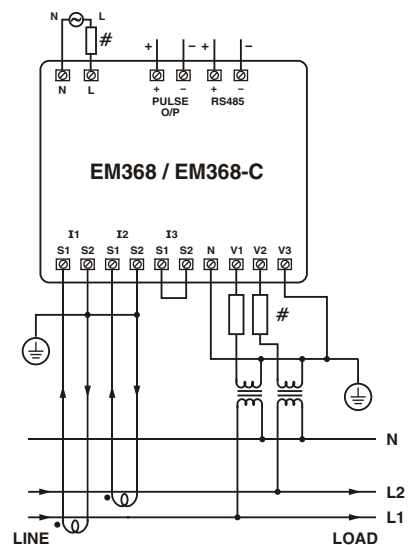

All fuse types : 0.5A class CC UL type
0.5A fast acting 600V

CONNECTION DIAGRAM FOR COMMUNICATION

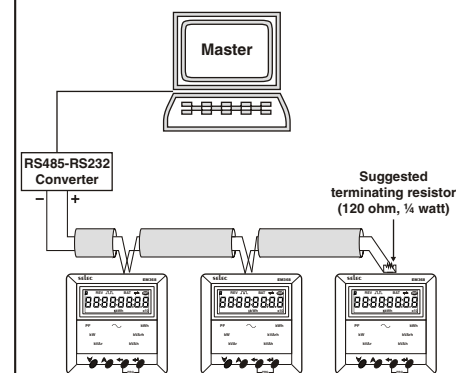

Contact sales for PC based monitoring software to communicate with the meters.

(Specifications subject to change as development is a continuous process.)

Selec Controls Pvt. Ltd., India
 Factory Address :
 EL-27/1, Electronic Zone, TTC Industrial Area,
 MIDC, Mahape, Navi Mumbai - 400 710, INDIA.
 Tel. No. : +91-22-28476443 / 1882
 Fax No. : +91-22-28471733 | Toll free : 1800 227 353
 Website: www.selec.com | Email: sales@selec.com