



Features :

- Panel Mount
- Accuracy : Class 1.0
- Input Current Ranges : 160A, 250A, 630A
- Rectangular Window Type

Input / Output Specifications

Rated Primary Current	160A, 250A, 630A
Rated Secondary Output	1A

Technical Specifications

Rated Burden	1VA
Class of Accuracy	1
Overload Current Continuous	120% of In Rated Current
System Voltage (Um)	720V max
Dielectric with Stand Voltage	3kV AC for 1 min
Nominal Rated Frequency	50 / 60Hz

Environmental Specifications

Temperature	0° to +50°C
Humidity (non condensing)	< 95% RH
Storage Temperature	-5° to +70°C

Mechanical Specification

Mounting	Panel
----------	-------

Dimension (in mm)

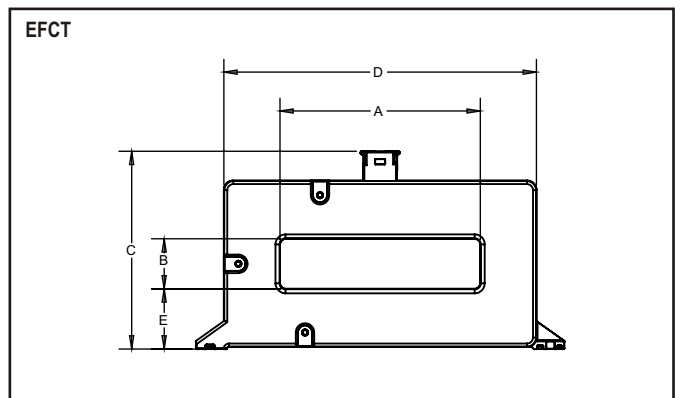

EFCT TYPE	Dimensions (mm)				
	A	B	C	D	E
EFCT 100X25	100	25	100	156	30
EFCT 140X35	140	35	114	201	32
EFCT 180X35	180	35	109	236	30
EFCT 220X50	220	50	128	276	32

Ordering Information

Product Code	Dimenssion in mm	Current Transformer Ratio
EFCT 100/25 160/1A VAL CL1	100 x 25	160/1A
EFCT 140/35 160/1A VAL CL1	140 x 35	160/1A
EFCT 140/35 250/1A VAL CL1	140 x 35	250/1A
EFCT 180/35 250/1A VAL CL1	180 x 35	250/1A
EFCT 180/35 630/1A VAL CL1	180 x 35	630/1A
EFCT 220/50 630/1A VAL CL1	220 x 50	630/1A