



48mm x 96mm

**FEATURES**

- PLC with built-in HMI
- Configurable LED display
- RS485 based communication with MODBUS RTU protocol

**SPECIFICATIONS**

Display	Top Red – 8 digits (7 segment)
	Bottom Green – 6 digits (7 segment)
	8 LED's (4 Red + 4 Green)
No. of Keys	5 (4-user configurable)
Supply Voltage	18V - 30 VDC

**FUNCTIONAL SPECIFICATIONS (CPU)**

Programming Language	Windows based user friendly SELPRO software for ladder logic programming.
Memory	Program Memory : 112 kB
	Data Memory : 16 kB
	EEPROM Memory : 2 kB
	VAR_INOUT & VAROUTPUT TYPE Variables : - Max 120 bytes retention
Scan Time	Typical 1ms (based on Ladder scan time)
Function Blocks	Timer On delay, Timer Off delay, Pulse Timer, Special Timer, Up/Down Counter, PID control etc.
Memory Retention	10 Years

**DIGITAL INPUTS**

\*1 = 90° Phase shift signals

Number of Digital Inputs	6 (Including 2 Fast Input)					
Operating Modes (user configurable)	Unidirectional / Bidirectional / Quadrature / Dual Unidirectional / None					
Channel	DI	MODE				
		UNI	BI	QUAD	DUAL UNI	None
FC0	I0	Rate Totalizer	Rate Totalizer	1st input*1	Rate Totalizer	Digital Input
	I1	Digital Input	Direction	2nd input*1	Totalizer	Digital Input
Operating Range	5 ~ 30V DC					
Input current	3 mA @10V					
Action Level	Level 1 → Level 0	<3V DC				
	Level 0 → Level 1	≥5V DC				
Response Time	Digital Input mode	Typical 1ms (based on ladder scan time)				
	Fast Input mode	100µsec				
Input Impedance	7.5 kΩ					
Debounce Time	0 ~ 255 ms (Default = 10 ms)					
Maximum counting Frequency (Fast Input)	5kHz					
Protection against polarity Inversions	Yes					

**RELAY OUTPUTS**

Number of Relay Outputs	4
Output Type	NO contact type
Output Current	5A @28VDC (Resistive)
	5A @240VAC (Resistive)
Response Time	10ms (based on ladder scan time)
Life Expectancy	30000 operation at full load
Isolation	No
Existence of common points between channels	1 COM for 4 Relay Outputs

**ANALOG INPUTS**

	TC Type	RTD Type
Number of channels	1 (user selectable)	
Sensor type	J, K, T, R, S, C, E, B, N, L, U, W, PLATINEL II, MILLIVOLT (-5 to 65mV)	PT100
Measurement Range	As per sensor selection	-99°C to 850°C
Temperature Resolution	0.1°C	
Digital Resolution for MILLIVOLT	12 bits	
Input impedance in signal range	560 kΩ	750 kΩ
Analog input error at 25°C	0.25% of full scale ±1°C	0.1% of full scale ±1°C
Absolute input range	5V	NA
Non linearity	0.25% of full scale ±1°C	0.1% of full scale ±1°C
Conversion time	100 ms	
Protection against polarity inversion	Yes	NA
Channel isolation	No	

**COMMUNICATION**

Communication Port	RS485 Slave
Communication Protocol	MODBUS RTU
Baud Rate	9600, 19200, 38400, 57600, 115200 (user configurable via software and hardware) Default = 19200 (Preferred ladder downloading at 19200)

**ENVIRONMENTAL CONDITIONS**

Operating Temperature	0 to 55°C
Storage Temperature	-20 to 70°C
Humidity (non-condensing)	95%
Mounting	Panel Mounted
Weight (g)	Approx. 200gms

**SAFETY PRECAUTIONS**

This manual is meant for personnel involved in wiring, installation, operation and routine maintenance of the equipment.  
All safety related conditions, symbols and instructions that appear in this operating manual or on the equipment must be strictly followed to ensure operator and instrument safety. Any misuse may impair the protection provided by the equipment.

**CAUTION** : Read complete instructions prior to installation and operation of the unit.

**CAUTION** : Risk of electric shock.

**INSTALLATION INSTRUCTIONS**

**CAUTION**

1. This equipment, being built-in-type, normally becomes a part of the main control panel and the terminals do not remain accessible to the user after installation.
2. Conductors must not come in contact with the internal circuitry of the equipment else it may lead to a safety hazard that may endanger life or cause electrical shock to the operator.
3. Circuit breaker or mains switch must be installed between the power source and supply terminals to facilitate power 'ON' or 'OFF' function.
4. The equipment shall not be installed in environmental conditions other than those specified in this manual.
5. Since this equipment forms part of the main control panel, its output terminals get connected to the host equipment. Such equipment shall also comply to EMI / EMC and safety requirements like CE standard procedure.
7. Thermal dissipation of equipment is met through ventilation holes provided on housing of equipment. Obstruction of these ventilation holes may lead to a safety hazard.
8. The output terminals shall be loaded strictly as per the values / range specified by the manufacturer.

**MECHANICAL INSTALLATION**

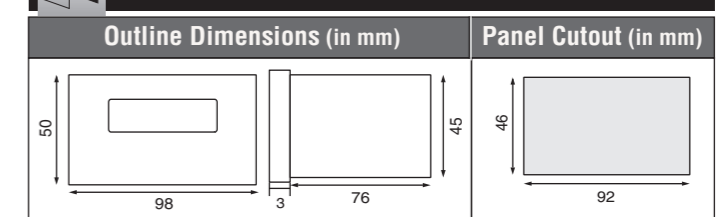

- For installing the controller
1. Prepare the panel cutout with proper dimensions as shown above.
  2. Fix the unit into the cutout. Insert the clamp from both sides and tighten the screws.

**CAUTION**

The equipment in its installed state must not come in proximity to any heating sources, caustic vapors, oils, steam or other unwanted process by products.

**EMC Guidelines :**

1. Use proper input power cables with shortest connections and twisted type.
2. Layout of connecting cables shall be away from any internal EMI source.

**MAINTENANCE :**

1. To avoid blockage of ventilation holes, clean the equipment regularly using a soft cloth.
2. Do not use Isopropyl alcohol or any other organic Solvents for cleaning.

**WIRING INSTRUCTIONS**

**CAUTION**

1. To prevent risk of electric shock, power supply to the equipment must be kept OFF while wiring.
2. Terminals and electrically charged parts must not be touched when the power is ON.
3. Wiring shall be done strictly according to the terminal layout provided in the operating manual.
4. To eliminate electromagnetic interference use short wire with adequate ratings and twists of equal size.
5. The power supply connection cable must have a cross section of 1sq.mm or greater and insulation capacity of at least 1.5KV.

**FUNCTIONAL DETAILS**

TWIX-1-24VDC is a PLC with built in HMI. The user can configure the product using SELPRO software.

**SELPRO has two sections :**

1. Ladder logic programming section
2. Selec Machine Interface, used for configuration of HMI.

For details of the software, please refer to the software user manual.

**INTERNAL PINOUT FOR COMMUNICATION RS485 PORT**

PIN	DESCRIPTION
1	RS485+ (Slave)
2	---
3	---
4	---
5	---
6	RS485- (Slave)

**WIRING DIAGRAM**

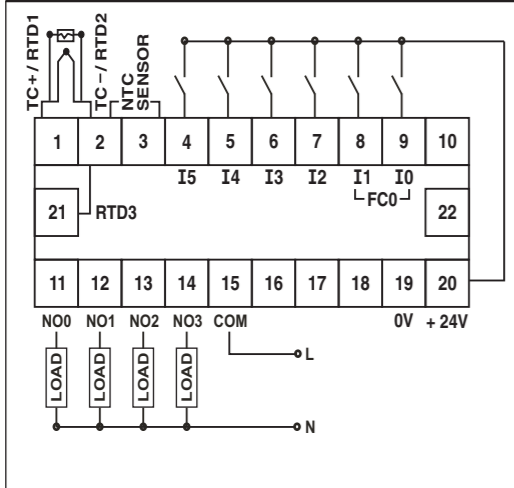

**MENU DESCRIPTION**

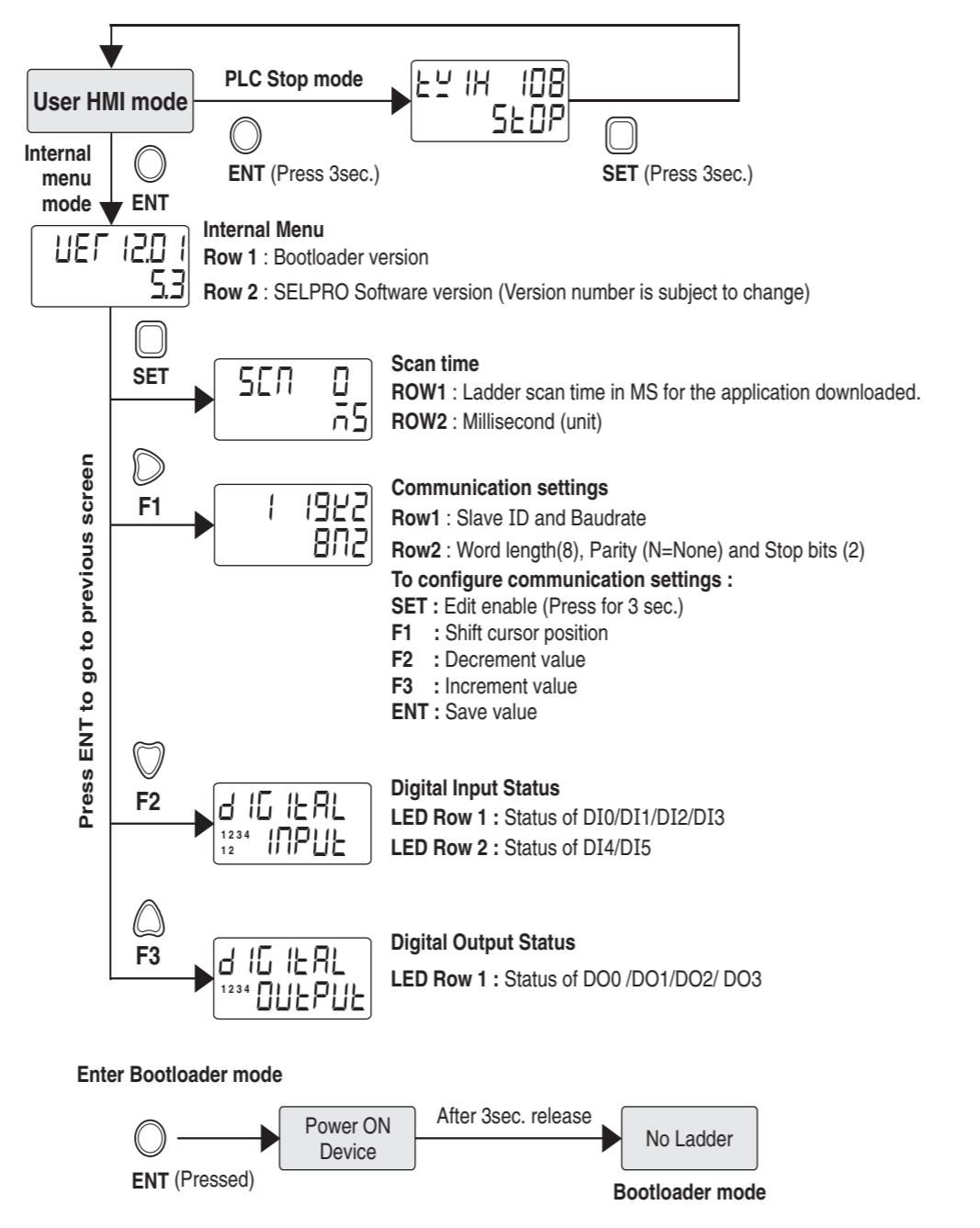

**ACCESSORIES (To be ordered separately)**

ORDER CODE	DESCRIPTION
AC-USB-RS485-03	USB to RS485 cable (6 pin jack for downloading)
AC-USB-RS485-02 *	USB to RS485 cable (2 pin open wire)
ACH-004	RJ25 (6-pin) cable
AC-IOEXP-02	Port Expansion adapter

**Note:** \* Along with ACH-004 & AC-IOEXP-02 for networking

**? SERVICE DETAILS**

This device contains no user serviceable parts and requires special equipment and specialized engineers for repair. Please contact service center for repair on the following numbers : **Tel. No. :** + 91-7498077172 ; **Email :** service@selec.com  
**NO WARRANTY ON UNIT DAMAGED DUE TO WRONG POWER SUPPLY.**

(Specifications are subject to change, since development is a continuous process.)

**Selec Controls Pvt. Ltd., India**

Factory Address :  
 EL-27/1, Electronic Zone, TTC Industrial Area, MIDC, Mahape, Navi Mumbai - 400 710, INDIA.  
 Tel. No. : +91-22-4148 419/430 | Fax No. : +91-22-28471733  
 Toll free : 1800 227 353 (BSNL/MTNL Subscribers only)  
 Website : www.selec.com | Email : sales@selec.com

**CALIBRATION CERTIFICATE**

**Model :- TWIX-1-24VDC**

Claimed Accuracy :- For TC :0.25% of full Scale ± 1°C  
 For RTD :0.1% of full Scale ± 1°C  
 For V & I :0.5% of full Scale

Traceability :-



This Units Has Been verified For All functional parameters mentioned in Operating Instruction.

**Analog Parameters [For Applicable Product]**

The Calibration of this unit has been verified at the following value for selection channels :-

Analog Input :-	CH0	CH1	CH2	CH3	CH4	CH5
TC						
RTD						
AI						
AV						

**NOTE :** Analog Input/Analog Output Has Been Verified At the following Value :

Sensor	Calibration Temp(°C)	Display Value(°C)	Sensor	Calibration Value	Display Value
K	35.0	35.0	Voltage (VDC)	0.000	0.000
	700.0	700.0		10.000	10.000
	1350.0	1350.0			
PT100	0.0	0.0	Current (mA)	0.000	0.000
	500.0	500.0		20.000	20.000
	800.0	800.0			

The thermocouple/RTD curves are Linearized in this microprocessor based product , and hence the value interpolated between the readings shown above are also equally accurate, at every point in the curve.

Product Calibration Is Traceable to NABL Standard.

Unit is accepted as accuracy is within the specified limit of claimed accuracy and certifiedis valid up to one year from the date of issue.