



96 x 96mm

Features :

- Leakage current monitoring in 1Ø and 3Ø systems
- CBCT connection detection
- User selectable Power ON delay, trip time delay and recovery time delay
- Adjustable switching hysteresis
- Test and reset function via front / remote
- Pre-alarm indication selectable
- Test & reset via front/remote

Display Specifications

Display	3 Digits 7 Segment LED Display
No. of LED	2
No. of Keys	3

LED Indication Chart

Condition	'mA' LED	'R' LED
No Fault	OFF*	OFF
Trip	OFF*	ON
CBCT Error	OFF*	ON
Pre-alarm	OFF*	Blinking

**:* : 'ON' only when 33mA / 550mA range is selected

Input Specifications

Functions	
Measurements	Earth Leakage Current Monitoring (via external CBCT)
Time Settings	Power ON delay, Trip time delay, Recovery time delay
Latching	Selectable
Reset	Auto / Manual (Selectable)
Electrical Connection	1Ø - 2 wire, 3Ø - 4 wire, 3Ø - 3 wire
Trip Settings	
Trip Leakage Current Range	30mA - 30A
Display Current Range	15mA - 33A
Trip Time Settings	
Power ON Delay	1 - 999sec
Trip Time Delay	0 - 999sec
Recovery Time Delay	1 - 99min
Response Time	< 30ms (If trip current = 5 x set value & Instantaneous trip is ON) < 50ms (If trip current = 1 x set value)
Hysteresis	
Hysteresis	5 to 40%
Resolution	
Current	0.1mA, 1mA, 0.01A, 0.1A (Depends on trip Setting)

Accuracy

Current	±5% of Setting
Time	±5% of Setting ±100ms

Output Specifications

No. of Relays	1
Type of Output (Relay)	1 C/O (SPDT)
Relay Rating	NO / 5A@250V AC / 28V DC NC / 3A@250V AC / 28V DC

Auxiliary Supply Specifications

Supply Voltage	90 - 270V AC / DC
Frequency	50 - 60Hz
Power Consumption	4VA max

Environmental Specifications

Temperature	Operating Temperature : 0° to 55°C Storage Temperature : -20° to +70°C
Humidity (non-condensing)	95% RH
Pollution Degree	
For PCB	2
For Product	3
Degree of Protection Devices	IP20

Mechanical Specifications

Mounting	Panel Mount
Size	96 x 96mm
Weight	250gms approx
Screw Tightening Torque	0.5 NM

Dimensions

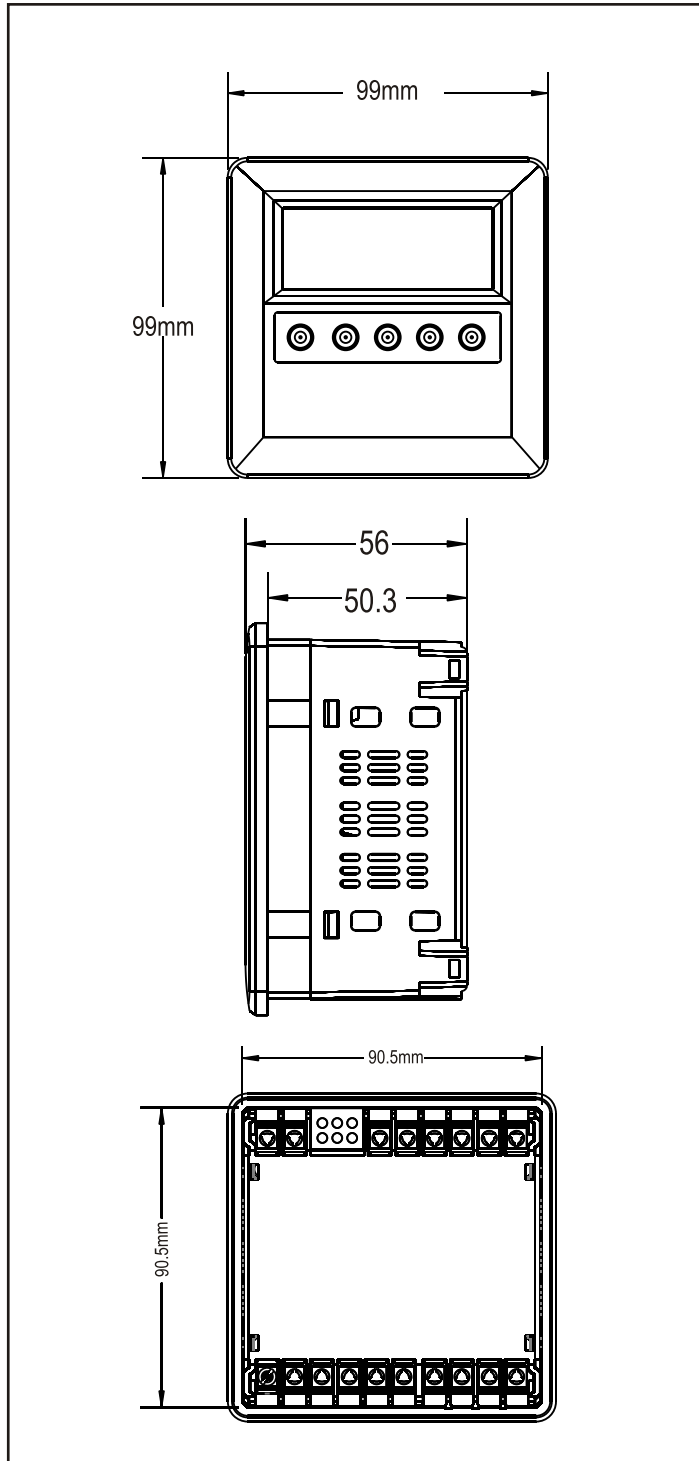

Terminal connections

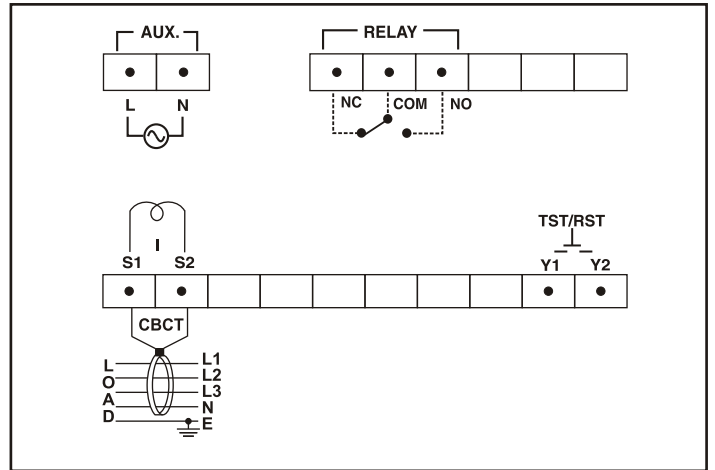

Ordering information

Product code	Supply Voltage	Certification
ELR-341-1	90 - 270V AC / DC	—

Accessories

Product code	Inner Diameter	Turns Ratio
CBCT-35-1	35mm	1000:1
CBCT-70-1	70mm	1000:1
CBCT-120-1	120mm	1000:1
CBCT-210-1	210mm	1000:1
CBCT-310-1	310mm	1000:1