



48 x 48

Please maintain these instructions and review them prior to using the unit :

Warning :

- This unit is panel mounted type with its output terminals getting connected to the host equipment. Such equipment shall also comply with basic EMI/EMC and safety requirements like BS EN 61326-1 and BS EN 61010 respectively.
- To avoid electric shock, power supply of the unit should be kept off while wiring. Wiring should be done strictly as per the terminal layout, given in the manual.
- Use lugged terminals to meet M3.5 screws.
- The unit does not have a built-in fuse. External fuse with a rating of 275V AC/1A is recommended.

Caution :

- This unit is not intended for outdoor use.
- The power connection cable must have a cross section of at least 1mm² and insulation capacity of at least 1.5kV.
- The output connections must not be loaded beyond the specified values/range.
- Avoid inflow of dust and contact of conductive material with the internal circuitry of the unit.
- The unit must not operate in presence of heating sources, caustic vapors, oil, steam, vibration or impact etc.
- Use clean moist cloth soaked in water for cleaning. Care must be taken to avoid entry of water into the circuitry through the ventilation holes.

SPECIFICATIONS

DISPLAY

Dual 4 digit 7 segment LED.
Upper Display(current value) : 0.5" height, Red color
Lower display(selectable) : 0.3" height, Green color

SUPPLY VOLTAGE (Factory Set)

90 to 270V AC/DC, 50/60Hz.
24V AC/DC

OPERATING MODES

Timer : Relay 1 : On delay, Interval, Cyclic On first, Cyclic Off first.

Relay 2 : On delay, Interval, Cyclic On first, Cyclic Off first, Batch.

Counter : Relay 1 : On delay, Interval, Auto reset, Time pulse repeat.

Relay 2 : On delay, Interval, Auto reset, Time pulse repeat, Batch.

TIME RANGES

Timer : 99.99 / 999.9 / 9999sec,
99:59min : sec,
999.9 / 9999min,
99:59hr : min 999.9 / 9999hr.

Counter : -999 to 9999 counts.

RESOLUTION

0.001, 0.01, 0.1, 1.

DIRECTION

Timer - Down.
Counter - Up / Down.

LED INDICATIONS

Output status, sec, min, hr.

SET POINTS

Dual.

START INPUT

Pulse start.

SENSOR INPUTS

3 to 30V DC from Proximity switches, Encoders,
Potential free contacts.

SENSOR SUPPLY

12V DC, 30mA (Short circuit protected).

INPUT SPEED

3 Hz, 30 Hz, 5 kHz.

SCALE FACTOR

0.001 to 9.999 x 10ⁿ
Where n = -3, -2, -1, 0, 1, 2.

RESET

On power interruption, Front panel reset,
Terminal reset.

OUTPUT

2 NO

RELAY RATING

5A@230V AC

MEMORY RETENTION

10 years.

ACCURACY

Timer : ±0.05% of setting or
50msec whichever is greater.

MOUNTING

Panel Mounting

TEMPERATURE

Operating : 0°C to 50°C
Storage : -20°C to 75°C
Humidity : 95% max.

HOUSING

Flame retardant plastic.

WEIGHT

175 grams (approx).

MECHANICAL INSTALLATION

OUTLINE Dimensions (in mm)		PANEL CUTOUT Dimensions (in mm)

TERMINAL CONNECTIONS

DESCRIPTION	TERMINAL
L (Live)	1
NO 1 - COM 1	2-3
NO 2 - COM 2	4-5
N(Neutral)	6
RESET input	7
+12V	8
START/CNT input	9
COM (GND)	10

FRONT PANEL DESCRIPTION

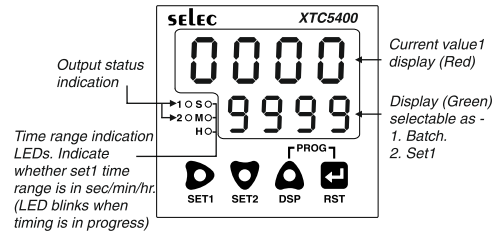

KEYS	FUNCTIONS
	Enter / Exit configuration mode
	1. Selects the digit to be altered. Selected digit blinks. With every press of key, next digit towards the right starts blinking. 2. Programming for Set1.
	1. Decrements value of blinking digit. 2. Scrolls down to previous option for configuration parameter. 3. Programming for set 2.
	1. Increments value of blinking digit. 2. Scrolls up to next option for configuration parameter. 3. Programming lower display options 4. Display Batch value.
	1. Scrolls to next config. parameter and stores for previous parameter setting. 2. Front panel RST.

JUMPER SELECTION FOR INPUT SENSOR :

INPUT SENSOR	JUMPER SELECTION
PNP / Potential free contact	
NPN	

NOTE : Same jumper selections remain valid for giving start pulse when using XTC5400 in Timer function.

JUMPER SELECTION TO DISABLE LOCK :

If the lock password is forgotten / lock feature is not required, connect jumpers as in fig. below to disable lock function. These Jumpers are located towards the right of the jumpers for sensor selection.

(Top view of jumpers with housing removed and display on right)

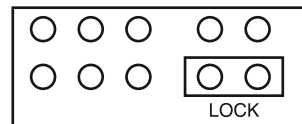

INPUT CONNECTIONS

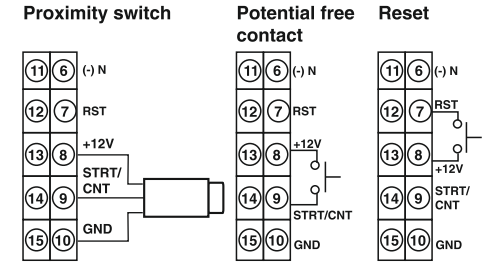

NOTE : Color codes for proximity sensors -
Brown / Red --> +12V,
Black / Green --> CNT,
Blue / Black --> GND

SCALE FACTOR

Programmable scale factor facilitates display in desired engineering unit. The number of count pulses received are multiplied with the scale factor and the result is displayed as shown :

Display = Number of pulses received x scale factor
Scale factor consists of two parts - mantissa & exponent. Mantissa can be set from 0.001 to 9.999 and exponent from -3 to +2. The scale factor value is arrived at as :

Scale factor = Mantissa x 10^{Exponent}

CONFIGURATION SCHEME :

NOTE : 1. Press to go to the next programming step and store the current programmed value in EEPROM.
2. If no key is pressed for 2min, the unit will auto-exit from configuration.

Upper Display	Lower Display	Description
Press + keys to enter configuration		
Configuration Lock	<i>Default : 0000.</i>	
		The configuration cannot be changed unless a valid lock ID is entered. Press to select the digit and / to change value of the selected digit
Press + keys to enter configuration		
Function		
		Function - Timer / Counter Timer : Unit functions as a timer Counter : Unit functions as a counter

SETTING OF TIMER FUNCTIONS :

Upper Display	Lower Display	Description
Press [Enter] key to enter programming for Time range.		
Time range		Default : 999.9 sec
[SEC]	99.99	Time ranges : 99.99sec, 999.9sec, 9999sec, 99:59min:sec , 999.9min, 9999min, 99:59hr:min, 999.9hr, 9999hr.
[.SEC]	99.59	
[.MIN]	999.9	
[.HR MIN]	99.59	
[HOUR]	999.9	
Press [Enter] key to enter programming for Relay 1 operating mode		
Relay 1 operating mode.		Default : ON Delay
[PLY1]	ON	Relay1 operating mode : ON Delay / Interval / Cyclic ON first / Cyclic OFF first. NOTE : Refer waveforms for details.
	INT	
	CY.ON	
	CY.OFF	
	CY.OF	
Press [Enter] key to enter programming for Relay 2 operating mode		
Relay 2 operating mode.		Default : ON Delay
[PLY2]	ON	Relay2 operating mode: ON Delay / Interval / Cyclic ON first / Cyclic OFF first / Batch. NOTE : Refer waveforms for details.
	INT	
	CY.ON	
	CY.OFF	
	BATCH	

Upper Display	Lower Display	Description
Press [Enter] key to enter programming for front panel batch reset		
Front panel batch reset.		Default : Yes
[FPbR]	YES	Front panel batch reset : Yes / No. Yes : Batch value can be reset from front panel. No : Batch value cannot be reset from front panel
	NO	
Press [Enter] key to enter programming for Batch reset		
Batch reset		Default : No
NOTE : Prompted only if Front panel batch reset is No.		
[bPSE]	YES	Batch reset : Yes and No. Yes : Batch value is reset immediately. No : Batch value is not reset.
	NO	
Press [Enter] key to enter programming for Front panel reset		
Front panel reset		Default : Yes
[FPR]	YES	Front panel reset : Yes / No. Yes : Unit can be reset from the front panel. No : Unit cannot be reset from the front panel.
	NO	
Press [Enter] key to enter programming for Power on reset		
Power on reset		Default : No
[POR]	NO	Power on reset ranges : Yes / No. Yes : Unit is reset on power interruption. No : Unit is not reset on power interruption.
	YES	
Press [Enter] key to enter programming for Reset all		
Reset all parameters to default		Default : No
[dFLE]	NO	Reset all parameters to default : Yes / No Yes : All parameters are set to factory set values. All set points are set to 0.
	YES	

PROGRAMMING - TIMER

Temporary display :
Lower display shows parameter name for 1sec. and then its value.

Enter programming as per the given procedure.

To program set points :

Press **[Enter]** to select the digit. The selected digit blinks. Press **[Up]** / **[Down]** key to change its value. Press **[Enter]** key to go to the next parameter (if applicable). If the edited parameter is the last parameter, the unit will quit programming.

To select lower display options :

Press **[Up]** / **[Down]** key to select particular option and then press **[Enter]** key to quit programming.

To select reset option :

Press **[Up]** / **[Down]** key to select particular option and then press **[Enter]** key for 1.5 sec to quit programming.

1. Programming for Set point1 :

Press Key	Lower Display
[Enter] for 1.5 sec to Enter Set1 programming. (Auto program out after 2min)	Applicable when Relay1 in On delay / Interval mode. Set point 1 SEET1 1234
Default : 10sec.	Applicable when Relay1 in Cyclic mode. Start Time ON Time OFF Time 1-5E 1-00 1-0F 1234 1234 1234 * * *

2. Programming for Set point2 :

Press Key	Lower Display
[Enter] for 1.5 sec to Enter Set2 programming. (Auto program out after 2min)	Applicable when Relay2 in On delay / Interval mode. Set point 2 SEET2 1234
Default : 9sec.	Applicable when Set2 in Cyclic mode. Start Time ON Time OFF Time 2-5E 2-00 2-0F 1234 1234 1234 * * *

3. Programming for Lower display options :

Press Key	Lower Display
[Enter] for 1.5 sec to Enter programming for Lower display options (Auto program out after 2min)	Batch Set point 1 BATCH SEET1 * * * Exit programming Exit programming

4. Programming for Reset :

Press Key	Lower Display
[Enter] for 1.5sec. to Enter / Exit programming for reset	Reset Batch reset PSE bPSE

NOTE : * sign indicates that the display blinks.

Read Function

Temporary display :
Lower display shows parameter name for 1sec and then its value.

1. Reading of set1 parameters

Press Key	Lower Display
[Enter] momentarily each time to read set 1 value. Auto exit from Read function if key is not pressed within 3 sec.	Applicable when Set1 in On delay / Interval mode. Set point 1 SEET1 1234
	Applicable when Set1 in Cyclic mode. Start time ON time OFF time 1-5E 1-00 1-0F 1234 1234 1234

2. Reading of set2 parameters

Press Key	Lower Display
[Enter] momentarily each time to read set 2 value. Auto exit from Read function if key is not pressed within 3 sec.	Applicable when Set2 in On delay / Interval mode. Set point 2 SEET2 1234
	Applicable when Set2 in Cyclic mode. Start time ON time OFF time 2-5E 2-00 2-0F 1234 1234 1234
	Applicable when Set2 in Batch mode. Set point 2 SEET2 1234

3. Reading Batch

Press Key	Lower Display
[Enter] momentarily to read batch value. Auto exit from Read function if key is not pressed within 3 sec.	4 digit Batch 6 digit Batch 1234 BATECH 12 Upper Display 3456 Lower Display
	6 digit batch can be read with 2MSDs on the upper display.

NOTE : When viewing 6 digit batch value, lower display LSD dp blinks and batch value is displayed for 3 sec. If lower display is selected as batch and batch value exceeds 4 digits, the lower display LSD dp is on continuously indicating that the batch value has exceeded 4 digits.

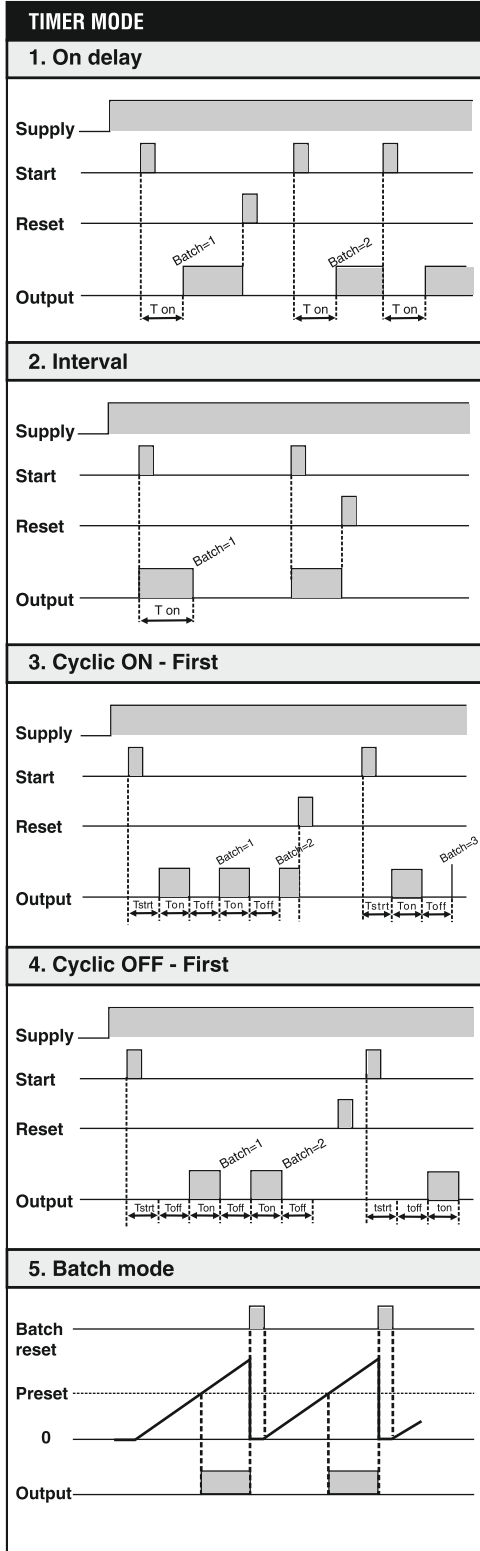

SETTING OF COUNTER FUNCTIONS :

Upper Display	Lower Display	Description
Press [F1] key to enter programming for Scale factor mantissa		
Scale factor mantissa	Default : 1.000	
SCL	1.000*	
Press [F2] key to enter programming for Scale factor Exponent		
Scale factor Exponent	Default : 0	
EPN	0*	Scale factor Exponent : 0 / 1 / 2 / -3 / -2 / -1.
	1*	
	2*	
	-3*	
	-2*	
	-1*	
Press [F3] key to enter programming for Resolution		
Resolution	Default : 1	
PESL	1	Resolution : 1 / 0.1 / 0.01 / 0.001.
	0.1	
	0.01	
	0.001	
Press [F4] key to enter programming for Maximum input speed.		
Maximum input speed.	Default : 30Hz	
SPd	5000	Speed : 3Hz / 30Hz / 5KHz.
	3	
	30	

Upper Display	Lower Display	Description
Press [F5] key to enter programming for Counting Direction		
Counting Direction	Default : UP	
dIPN	UP DOWN	Direction : Up and Down Up : Counting starts from 0 and proceeds towards set point. Down : Counting starts from set point and proceeds down to 0.
Press [F6] key to enter programming for Relay 1 operating mode		
Relay 1 operating mode	Default : ON Delay	
PLY1	ON INT	Relay1 operating mode : ON delay / Interval. NOTE : Refer waveforms for details.
Press [F7] key to enter programming for Relay 2 operating mode		
Relay 2 operating mode	Default : ON Delay	
PLY2	ON INT BATCH	Relay2 mode ranges : ON delay / Interval / Batch.
Press [F8] key to enter programming for Run mode		
Run mode	Default : Over run	
PUN	OP NOP	Run mode ranges : Overrun / Non overrun. Overrun : Counter continues counting above the set point. Non Overrun : Counter does not count any pulses received after reaching the set point.
Press [F9] key to enter programming for Operating mode		
Operating mode	Default : Delay	
NOdE	dLY AP tPP	Operating mode ranges: Delay / Auto reset / Time pulse repeat. NOTE : Refer waveforms for details.

Upper Display	Lower Display	Description
Press [F10] key to enter programming for Front panel batch reset		
Front panel batch reset	Default : Yes	
FPbR	YES NO	Front panel batch reset : Yes / No. Yes : Batch value can be reset from front panel. No : Batch value cannot be reset from front panel
Press [F11] key to enter programming for Batch reset		
Batch reset	Default : No	
BPSE	NO YES	Batch reset : Yes and No. Yes : Batch value is reset immediately No : Batch value not is reset
Press [F12] key to enter programming for Front panel reset.		
Front panel reset.	Default : Yes	
FPnR	YES NO	Front panel reset : Yes / No. Yes : Unit can be reset from the front panel No : Unit cannot be reset from the front panel
Press [F13] key to enter programming for Power on reset.		
Power on reset.	Default : No	
POP	NO YES	Power on reset ranges : Yes / No. Yes : unit is reset at power ON. No : Unit is not reset at power ON.
Press [F14] key to enter programming for Reset all.		
Reset all parameters to default	Default : No	
dFLE	NO YES	Reset all parameters to default : Yes & No Yes : All parameters are set to factory set values. All set points are set to 0.

NOTE : * sign indicates that the display blinks.

PROGRAMMING - COUNTER

Temporary display :
Lower display shows parameter name for 1sec. and then its value.

Enter programming as per the given procedure.

To program set points :

Press **▶** to select the digit. The selected digit blinks.
Press **▼/▲** key to change its value. Press **▶** key to go to the next parameter (if applicable). If the edited parameter is the last parameter, the unit will quit programming.

To select lower display options :

Press **▼/▲** key to select particular option and then press **▶** key to quit programming.

To select reset option :

Press **▼/▲** key to select particular option and then press **▶** key for 1.5 sec to quit programming.

1. Programming for Set point 1 :

Press Key	Lower Display
▶ for 1.5 sec to Enter / Exit online programming for Set1. (Auto program out after 2min)	Applicable when Set1 in On delay / Interval mode. Set point 1 SEET1 * 1234
	Applicable when Set1 in On delay / Interval mode + Auto reset mode. Set point 1 Auto reset time SEET1 AR * * 1234 1234 * * Exit Set point1 programming Autoreset time range : 0 to 999.9 sec.
	Applicable when Set1 in On delay / Interval mode + Time Pulse Repeat. Set point 1 Time pulse repeat SEET1 TPR * * 1234 1234 * * Exit Set point1 programming TPR time range : 0 to 999.9 sec.

Default : 100 AR / TPR time = 10sec

2. Programming for Set point 2 :

Note : Set2 should always be less than Set1, except when Set 2 is in Batch mode.

Press Key	Lower Display
▼ for 1.5 sec to Enter / Exit online programming for Set2. (Auto program out after 2min)	Applicable when Set2 in On delay / Interval mode. Set point 2 SEET2 * 1234
	Applicable when Set2 in Batch mode. Set point 2 SEET2 * 1234

Default : 90.

3. Programming for Lower display options.

Press Key	Lower Display
▶ for 1.5sec to Enter programming for lower display. (Auto program out after 2min)	Batch 6ECC * Exit programming Set point 1 SEET1 * Exit programming

4. Programming for Reset.

Press Key	Lower Display
▶ for 1.5sec to Enter / Exit online programming for reset	Reset RSE * Batch Reset BRSE * Exit programming

Read Function

Temporary display :
Lower display shows parameter name for 1sec and then its value

1. Reading of set1 parameters

Press Key	Lower Display
▶ momentarily each time to read Set1 value.	Applicable when Set1 in On delay / Interval mode. Set point 1 SEET1 * 1234
Auto exit from Read function if key is not pressed within 3 sec.	Applicable when Set1 in On delay / Interval mode + Autoreset mode. Set point 1 Autoreset time SEET1 AR * * 1234 1234 * * Exit Set point1 programming
	Applicable when Set1 in On delay / Interval mode + Time Pulse Repeat. Set point 1 Time pulse repeat SEET1 TPR * * 1234 1234 * * Exit Set point1 programming

2. Reading of set2 parameters

Press Key	Lower Display
▼ momentarily each time to read Set 2 value. Auto exit from Read function if key is not pressed within 3 sec.	Applicable when Set2 in On delay / Interval mode. Set point 2 SEET2 * 1234

3. Reading Batch

Press Key	Lower Display
▶ momentarily each time read Set 2 value. Auto exit from Read function if key is not pressed within 3 sec.	4 digit Batch 1234 6 digit Batch 6ECC Upper Display 12 Lower Display 3456 6 digit batch can be read with 2MSDs on the upper display.

NOTE : When viewing 6 digit batch value, lower display LSD dp blinks and batch value is displayed for 3 sec. If lower display is selected as batch, and batch value exceeds 4 digits, the lower display LSD dp is on continuously indicating that the batch value has exceeded 4 digits.

COUNTER MODE

1. ON Delay (Overrun mode)

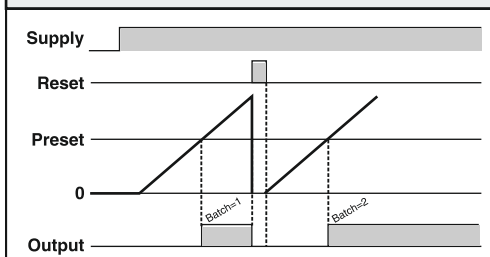

2. Interval (Overrun mode)

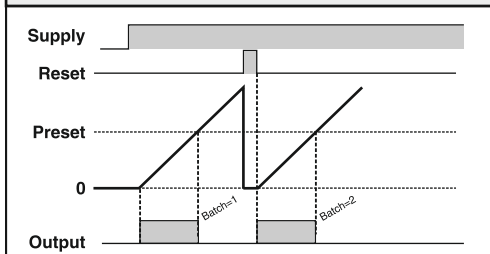

3. Auto Reset (Non Overrun mode)

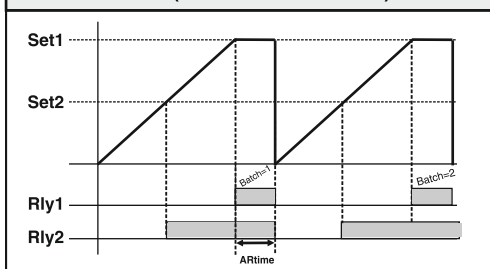

4. Time Pulse Reset (Non Overrun mode)

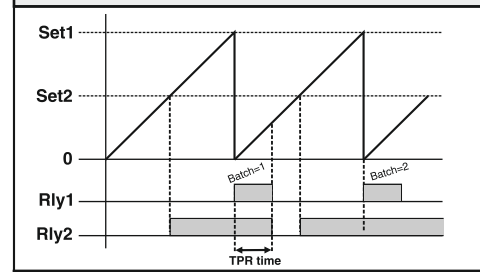

5. Batch mode

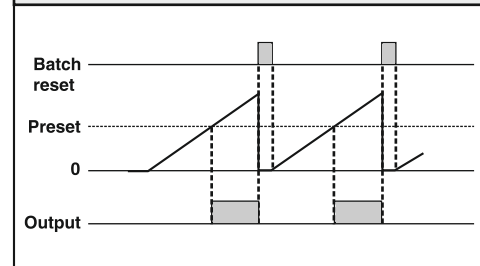

NOTE : * sign indicates that the display blinks.

(Specifications subject to change as development is a continuous process.)

Selec Controls Pvt. Ltd., India

Factory Address :
EL-27/1, Electronic Zone, TTC Industrial Area,
MIDC, Mahape, Navi Mumbai - 400 710, INDIA.
Tel. No. : +91-22-28476443 / 1882
Fax No. : +91-22-28471733 | Toll free : 1800 227 353
Website: www.selec.com | Email: sales@selec.com

Disclaimer : "This product is strictly for industrial use and for sale in non European countries only"