

SELEC VAF36A / VAF39A / VAF39A-1
Operating Instructions



SPECIFICATIONS

- Display**
VAF36A : 3 rows of 3 digit, Liquid Crystal Display 0.56 inch digit height
VAF39A : 3 rows of 3 digit, 7 segment LED display 0.56 inch digit height
VAF39A-1 : 3 rows of 3 digit, 7 segment LED display 0.58 inch digit height integrated with parameter units
- LCD Indications (VAF36A)**
 1) LCD indications for all measuring parameter (V, I, F)
 2) Bargraph indicates amount of % current present in the system (Independent of key press)
- LED Indications (VAF39A/ VAF39A-1)**
 LED indications for all measuring parameter (V, I, F)
- Wiring Input**
 3Ø - 3 wire and 3Ø - 4 wire system
- RATED INPUT VOLTAGE**
 11 to 300V AC (L-N) ; 19 to 519V AC (L-L) ; Installation Category III (600V)
UL Approval :
 11 to 277V AC (L-N) ; 19 to 480V AC (L-L) ; Installation Category III (600V)
- Frequency Range** : 50 / 60 Hz
Rated Input Current
 Nominal 5A (Min-20mA, Max-6A)
 (For VAF39A-1 : Min-30mA)
- CT Primary**
 5A to 10,000A (Programmable for any value)
CT Secondary : 5A (Fixed)
PT Primary
 100V to 500kV (Programmable for any value)
PT Secondary
 100 to 500V AC (L-L) (Programmable for any value)
- Display update time**
 1 sec. for all parameters
- Display Scrolling**
 Automatic or Manual (Programmable)
- POWER CONSUMPTION** : 5VA
RPM
 1350 - 1950 [Pole : 0 (Range : 0 - 98,selectable in steps of 2), Frequency : 45 - 65Hz]
Run Hour : 0 - 99999.9 hr
Burden : 0.5VA @ 5A per phase

- Resolution**
 1. For current and voltage, resolution depends on CT and PT primary setting
 2. For RPM, resolution is 0.1
 3. For Run Hour, resolution is 0.1hr
- ENVIRONMENTAL CONDITIONS**
 - Indoor use
 - Altitude of up to 2000 meters
 - Pollution degree II
- Temperature : Operating: -10°C to 55°C
 Storage : -20°C to 75°C
 Humidity : Up to 85% non-condensing
- PROTECTION CLASS** : II
- Mounting**
 Panel Mounting
- Weight**
 VAF36A : 357 gms ; VAF39A-1 : 344 gms ;
 VAF39A : 367 gms ; VAF39A-1-60VDC : 244 gms.

| ORDER CODE INFORMATION | | | |
|------------------------|--------------------------|---------------|-------|
| Product | Supply | Certification | |
| | | CE | eURus |
| VAF36A-110V-CE | 110V AC, ±20%, 50 / 60Hz | ■ | — |
| VAF36A-230V-CE | 230V AC, ±20%, 50 / 60Hz | ■ | — |
| VAF36A-110V-CU | 110V AC, ±20%, 50 / 60Hz | ■ | ■ |
| VAF36A-230V-CU | 230V AC, ±20%, 50 / 60Hz | ■ | ■ |
| VAF39A-110V-CU | 110V AC, ±20%, 50 / 60Hz | ■ | ■ |
| VAF39A-230V-CE | 230V AC, ±20%, 50 / 60Hz | ■ | — |
| VAF39A-230V-CU | 230V AC, ±20%, 50 / 60Hz | ■ | ■ |
| VAF39A-1-230V | 230V AC, ±20%, 50 / 60Hz | — | — |
| VAF39A-1-60VDC | 20V to 60V DC | — | — |

Installation Category II

| Parameters | Description | Unit |
|--------------------|--|-------|
| Voltage (True RMS) | All phase to phase, phase to neutral and average | V, kV |
| Current (True RMS) | All phases and average | A, kA |
| Frequency | Frequency of present phase | Hz |
| Run Hour | The time for which meter is on | H : M |
| RPM | RPM calculated from system frequency | — |

ACCURACY TABLE

| Measurement | Accuracy |
|---------------------------|------------------------|
| Voltage V_{L-N} | ±0.5% of F.S. ±2 digit |
| Voltage V_{L-L} | ±0.5% of F.S. ±2 digit |
| Average Voltage V_{L-N} | ±0.5% of F.S. ±2 digit |
| Average Voltage V_{L-L} | ±0.5% of F.S. ±2 digit |
| Current | ±1% of F.S. ±2 digit |
| Average current | ±1% of F.S. ±2 digit |
| Frequency | ±0.1Hz ±1digit |
| Run Hour | ±1% |
| RPM | ±0.5% |

SAFETY PRECAUTIONS

- All safety related codifications, symbols and instructions that appear in this operating manual or on the equipment must be strictly followed to ensure the safety of the operating personnel as well as the instrument.
- If the equipment is not used in a manner specified by the manufacturer it might impair the protection provided by the equipment.
- Do not use the equipment if there is any mechanical damage.
 - Ensure that the equipment is supplied with correct voltage.

- CAUTION :**
- Read complete instructions prior to installation and operation of the unit.
 - Risk of electric shock.
 - The equipment in its installed state must not come in close proximity to any heating sources, oils, steam, caustic vapors or other unwanted process by products.

WIRING GUIDELINES

- WARNING :**
- To prevent the risk of electric shock, power supply to the equipment must be kept OFF while doing the wiring arrangement.
 - Wiring shall be done strictly according to the terminal layout. Confirm that all connections are correct.
 - Use lugged terminals.
 - To reduce electromagnetic interference use of wires with adequate ratings and twists of the same in equal size shall be made with shortest connections.
 - Layout of connecting cables shall be away from any internal EMI source.
 - Cable used for connection to power source, must have a cross section of 0.5mm² to 2.5mm² (20 to 14AWG ; 75°C (min)). These wires shall have current carrying capacity of 6A.
 - Copper cable should be used (Stranded or Single core cable).
 - Before attempting work on device, ensure absence of voltages using appropriate voltage detection device.

INSTALLATION GUIDELINES

- CAUTION :**
- This equipment, being built-in-type, normally becomes a part of main control panel and in such case the terminals do not remain accessible to the end user after installation and internal wiring.
 - Conductors must not come in contact with the internal circuitry of the equipment or else it may lead to a safety hazard that may in turn endanger life or cause electrical shock to the operator.
 - Circuit breaker or mains switch must be installed between power source and supply terminals to facilitate power 'ON' or 'OFF' function. However this switch or breaker must be installed in a convenient position normally accessible to the operator.
 - Before disconnecting the secondary of the external current transformer from the equipment, make sure that the current transformer is short circuited to avoid risk of electrical shock and injury.
 - The equipment shall not be installed in environmental conditions other than those mentioned in this manual.
 - The equipment does not have a built-in-type fuse. Installation of external fuse of rating 275V AC / 0.5Amp for electrical circuitry / battery is highly recommended.

MECHANICAL INSTALLATION

- For installing the meter
- Prepare the panel cutout with proper dimensions as shown below.
 - Push the meter into the panel cutout. Secure the meter in its place by fitting the clamp on the rear side. fit clamps on both sides in diagonally opposite location for optimum fitting.
 - For proper sealing, tighten the screws evenly with required torque.
 Terminal screw tightening torque :
 0.68 N-m to 0.79 N-m (6.018 In-Lb to 6.992 In-Lb)
 Screw clamp tightening torque : 0.1N-m (0.885 Lb-inch)

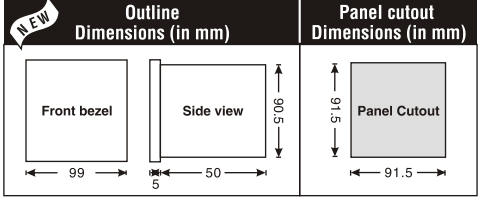

- MAINTENANCE**
- The equipment should be cleaned regularly to avoid blockage of ventilating parts.
 - Clean the equipment with a clean dry or damp cloth. Do not use any cleaning agent other than water.

TERMINAL CONNECTIONS

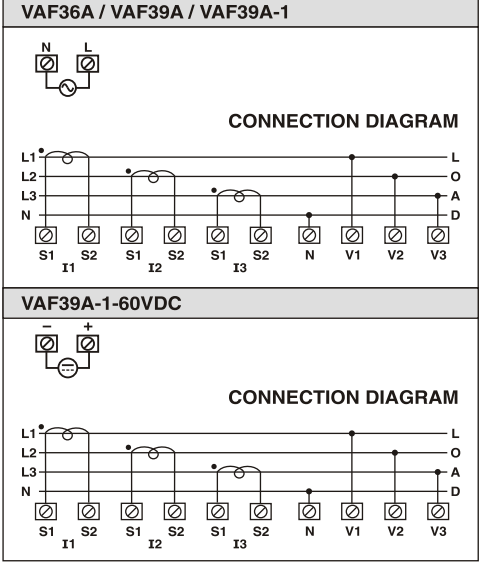

AUTOMATIC / MANUAL MODE DESCRIPTION

Press A/M button for 3 sec. to toggle between Automatic and Manual mode.

Note : By default unit operates in automatic mode. In automatic mode online pages scroll automatically at the rate of 5sec. per page. In automatic mode when any key is pressed, unit temporarily switches to manual mode and the appropriate page is displayed, also if no key is pressed for 5 sec., unit resumes automatic mode.

FRONT PANEL DESCRIPTION



ONLINE PAGE DESCRIPTION

There are 3 dedicated keys labelled as V, I, VAF. Use these 3 keys to read meter parameters. Simply press these keys to read the parameters.

| KEY PRESS | ONLINE PAGE DESCRIPTION |
|--------------------------------|--|
| Press "VAF" | <p>For 3 Ø-4 wire system :</p> <p>The first screen : Displays line to neutral voltage, current, frequency of first phase.</p> <p>The second Screen : Displays line to neutral voltage, current, frequency of second phase.</p> <p>The third Screen : Displays line to neutral voltage, current, frequency of third phase.</p> <p>The fourth Screen : Displays average line to neutral voltage, average current of three phases and frequency.</p> <p>The fifth Screen : Displays average line to line voltage, average current of three phases and frequency.</p> <p>For 3 Ø-3 wire system :</p> <p>The first screen : Displays line to line voltage, current, frequency of first phase.</p> <p>The second Screen : Displays line to line voltage, current, frequency of second phase.</p> <p>The third Screen : Displays line to line voltage, current, frequency of third phase.</p> <p>The fourth Screen : Displays average line to line voltage, average current of three phases and frequency.</p> |
| Press "I / h" | <p>The first screen : Displays phase current of three phases.</p> |
| Press "I / h" for 3sec. | <p>Displays Run Hour (for non zero poles)</p> <p>Note : To return back to current page, press "I / h" for 3sec.</p> |
| Press "V / r" | <p>The first screen : Displays line to neutral voltage of three phases.</p> <p>The second screen : Displays line to line voltage of three phases.</p> <p>Note : For 3 Ø 3 wire system, only the second screen will be available.</p> |
| Press "V / r" for 3sec. | <p>Displays RPM (for non zero poles)</p> <p>Note : To return back to voltage page, press "V / r" for 3sec.</p> |

SERIAL NUMBER DESCRIPTION

Press VAF and I / h key for 20sec. to display 8 digit serial number only for 10sec.

CONFIGURATION

There are 3 dedicated keys marked as A/M, ▲, ▼. Use these 3 keys to enter into configuration menu / change setting.

Note : The settings should be done by a professional, after going through this users manual and after having understood the application situation.

For the configuration setting mode :

- Press ▲ + ▼ key for 3 sec. to enter or exit from the configuration menu.
- Press ▲ or ▼ key to scroll through the setting pages.
- Press A/M + ▼ or A/M + ▲ Keys to decrement or Increment (change) the parameter setting.

| Config. page | Function | Range or Selection | Factory Setting |
|--------------|-------------------|--------------------|-----------------|
| 1 | Network Selection | 3P3W and 3P4W | 3P4W |
| 2 | CT primary | 5A or 10.0kA | 5 |
| 3 | PT primary | 100V to 500kV | 350 |
| 4 | PT secondary | 100V to 500V | 350 |
| 5 | No. of Poles | 0 - 98 | 0 |
| 6 | Reset Run Hour | Yes / No | No |

TYPICAL WIRING DIAGRAM

3 Phase - 4 Wire (Commonly Used)

3 Ø - 4 wire, 3 CT's
Network Selection : 3P4W

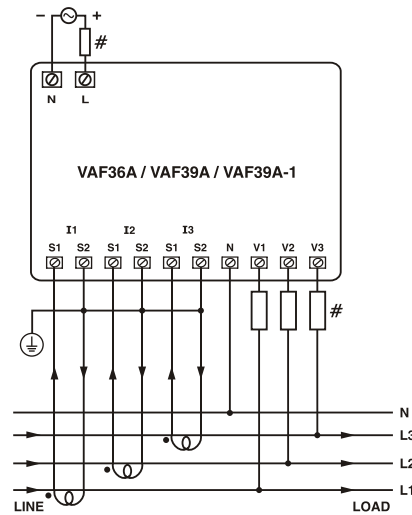

TYPICAL WIRING DIAGRAM

All fuse types : 0.5A class CC UL type ; 0.5A fast acting 600V

3 Phase - 4 Wire

3 Ø - 4 wire, 3 CT's and 3 PT's
Network Selection : 3P4W

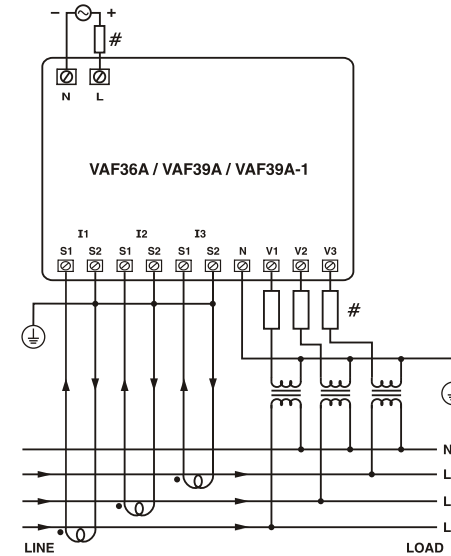

3 Phase - 3 Wire

3 Ø - 3 wire, 2 CT's and 2 PT's
Network Selection : 3P3W

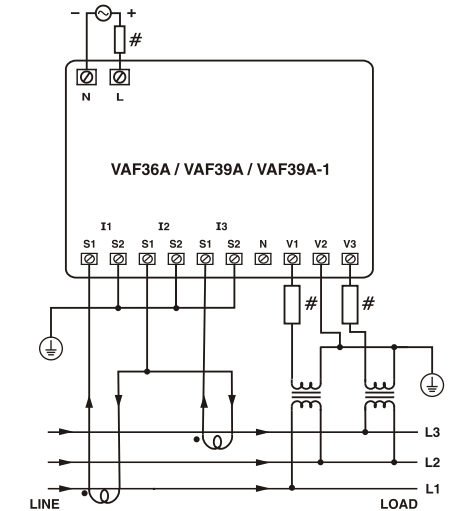

Note : + and - is applicable only for DC Product.

2 Phase - 3 Wire

2 Ø - 3 wire, 2 CT's 2 PT's
Network Selection : 3P4W

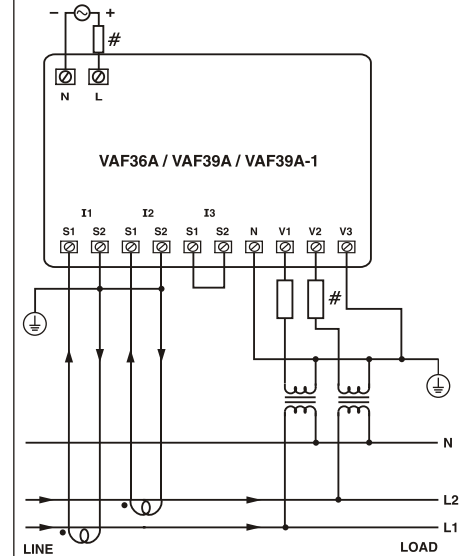

1 Phase - 2 Wire

1 Ø - 2 wire, 1 CT
Network Selection : 3P4W

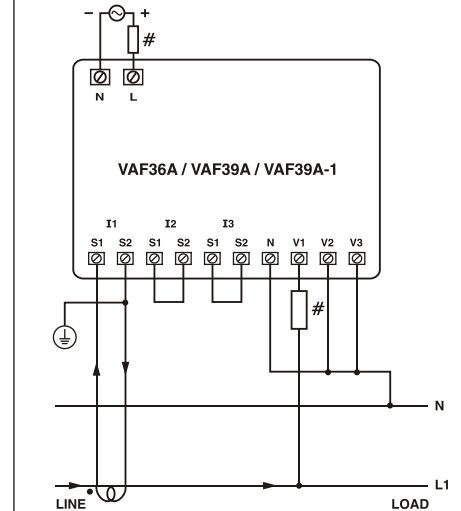

(Specifications subject to change as development is a continuous process.)

Selec Controls Pvt. Ltd., India

Factory Address :
EL-27/1, Electronic Zone, TTC Industrial Area,
MIDC, Mahape, Navi Mumbai - 400 710, INDIA.
Tel. No. : +91-22-28476443 / 1882
Fax No. : +91-22-28471733 | Toll free : 1800 227 353
Website: www.selec.com | Email: sales@selec.com