

OPERATING INSTRUCTIONS

800POD



Please maintain these instructions and review them prior to using the unit:

⚠ Warning :

- The Equipment is built-in type with Class II construction and is protected by Reinforced Insulation. Terminals are a part of the front panel and are protected by means of finger guards. Finger guards are not to be removed during wiring, installation, operation or maintenance.
- The power should be turned off while wiring and maintenance to prevent the risk of electric shock. Do not touch any terminals when the power is ON.
- Wiring shall be done strictly according to the terminal layout with shortest connections.
- Fuse Protection: The equipment does not have Built-in fuse. External fuse of rating 275 VDC/1 A is recommended.

⚠ Caution:

- This unit is not intended for outdoor use.
- The power connection cable must have a cross-section of at least 1sq.mm and insulation capacity of at least 1.5kV. Use lugged terminals to meet M3 screws.
- The output connections must not be loaded beyond the specified values/range.
- Avoid inflow of dust and contact of conductive material with the internal circuitry of the unit.
- Clean the equipment with a clean, soft cloth. Do not use any organic solvents for cleaning.

SPECIFICATIONS

Supply Voltage

110 V to 240 VAC. (tolerance : -15 to +10% AC: 50 or 60 Hz).

Delay Modes

True power off delay.

Time range

180 sec (factory set).

Output Contact

2 NO/NC.

Accuracy

Setting: $\pm 10\%$ of full scale.
Repeat: $\pm 2\%$ or 100 msec whichever is greater.

Led indication

Power 'ON'.

Reset time

100 ms.

Relay rating

2.5 A @250 VAC / 28 VDC,
Resistive load $\pm 10\%$ for both V & I.

Mounting

Din rail / Screw mounting.

Size (in mm)

22.5(W) x 75(H) X 101(D).

Housing

CE marked products: Flame retardant plastic.

Non CE products: ABS plastic.

Temperature

Operating: 0°C to 50°C.

Storage: - 20°C to 75°C.

Humidity

Up to 95% RH.

Weight

115 grams.

PANEL DIMENSIONS

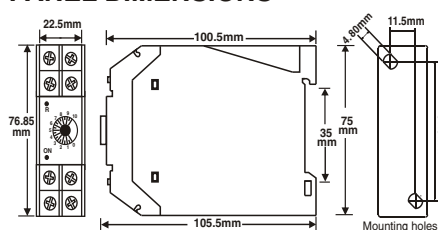

TYPICAL LOAD CONNECTIONS

1. For load current less than 0.5A

2. For bigger loads, use interposing relay / Contactor

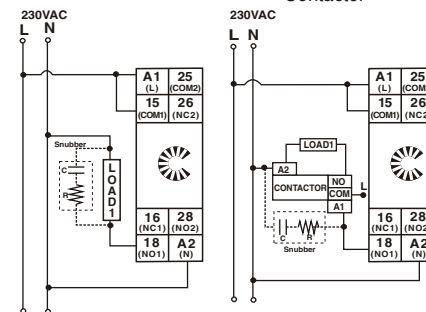

1) Snubber Part No.: APRC - 01.

2) MOV Part No.: AP-MOV - 03.

Note: Use snubber as shown above to increase the life of internal relay.

TERMINAL CONNECTIONS

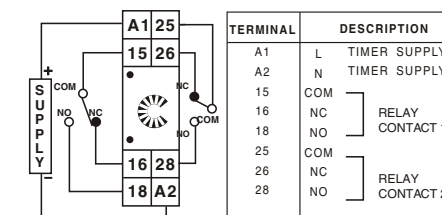

OPERATING MODE:

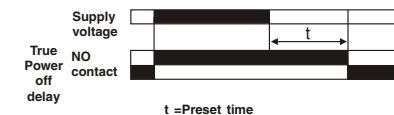

(Specifications subject to change as development is a continuous process)

SELECTRON Process Controls Pvt. Ltd., India,
Tel : 91-22-28476443, Fax:91-22-28471733,
Website: www.selecindia.com; E- mail: sales@selecindia.com