



SPECIFICATIONS

Display	: 1 st row of 4 digits to show electrical parameters 2 nd row of 7digits to show electrical parameters 3 rd row of 7digits to show electrical parameters : Liquid crystal display with backlight. : Digit integrated with parameter units.
LED Indications	: INT - Integration of energy INT1 1000 Pulses/kWh (Fixed) INT2 1/10/100/1000 Pulses/kWh or Pulses/kVAh (Configurable)
LCD Indications	: - Communication in progress MD - Maximum Demand of Power
Wiring Input	: 3Ø - 4W, 3Ø - 3W ,1Ø - 2W
Rated Input Voltage	: 85-285V AC (L-N) } Self-Powered 148-494V AC (L-L)
Frequency Range	: 45Hz to 65Hz
Rated Input Current	: I _b = 10A, I _{min} = 500mA, I _{max} = 100A
Display Update Time	: 1 sec for all parameters
Display Scrolling	: Auto / Manual / Default (Programmable)
Power Consumption	: Less than 8VA
Environmental Conditions	: Indoor use Altitude up to 2000 meters Pollution degree II
Temperature	: Operating : -10°C to 55°C Storage : -20°C to 70°C
Humidity	: Upto 85% (non - condensing)
Mounting	: Din rail mounting
Weight	: 400gms
Communication	: RS485 MODBUS RTU
Accuracy Class	: Class 1 for Active energy
Output	: POP Voltage range : External 24V DC max Current capacity : 100mA max
Tightening Torque	: 1.5 Nm to 2 Nm

ORDER CODE INFORMATION

Product	Output	Certification
EM4M-3P-C-100A	RS485 (Modbus RTU) & Pulse O/P	CE

SERIAL COMMUNICATION

Interface standard and protocol	RS485 AND MODBUS RTU
Communication address	1 to 255
Transmission mode	Half duplex
Data types	Float & Integer
Transmission distance	500 meter maximum
Transmission speed	2400, 4800, 9600, 19200, 38400 (in bps)
Stop bits	1 or 2
Parity	None, Odd, Even

ACCURACY

Measurement	Accuracy
Voltage V _{L-N}	±0.5% of Full scale
Voltage V _{L-L}	±0.5% of Full scale
Current	±0.5% of I _b
Power Factor	±0.01 of Full scale
Frequency	±0.1% of Full range
Active Power	1.00% of Full range
Reactive Power	1.00% of Full range
Apparent Power	1.00% of Full range
Active Energy	Class 1 (IEC 62053-21)
Reactive Energy	Class 2 (IEC 62053-23)
Demand Active Power	1.00% of Full range
Demand Reactive Power	1.00% of Full range
Demand Apparent Power	1.00% of Full range

RESOLUTION

Energy	0.01k
--------	-------

Note: For voltage, current & power resolution is adjusted automatically.
For power factor resolution is 0.01

SAFETY PRECAUTIONS

All safety related notifications, symbols and instructions that appear in this operating manual or on the equipment must be strictly followed to ensure the safety of the operating person as well as the instrument.

If the equipment is not used in a manner specified by the manufacturer it might impair the protection provided by the equipment.

- Do not use the equipment if there is any mechanical damage.
- Ensure that the equipment is supplied with correct voltage.

CAUTION :

1. Read complete instructions prior to installation and operation of the unit.
2. Risk of electric shock.
3. The equipment in its installed state must not come in close proximity to any heating sources, oils, steam, caustic vapors or other unwanted process by products.

WIRING GUIDELINES

WARNING :

1. To prevent the risk of electric shock, power supply to the equipment must be kept OFF while doing the wiring arrangement.
2. Wiring shall be done strictly according to the terminal layout. Confirm that all connections are correct.
3. Use lugged terminals.
4. To reduce electromagnetic interference use of wires with adequate ratings and twists of the same in equal size shall be made with shortest connections.
5. Layout of connecting cables shall be away from any internal EMI source.
6. Cable used for connection to power source, must have a cross section of 35mm²(2AWG ; 75°C(min)).
7. Copper cable should be used (Stranded or Single core cable).
8. Before attempting work on device, ensure absence of voltages using appropriate voltage detection device.

INSTALLATION GUIDELINES

CAUTION :

1. This equipment, being built-in-type, normally becomes a part of main control panel and in such case the terminals do not remain accessible to the end user after installation and internal wiring.
2. Conductors must not come in contact with the internal circuitry of the equipment or else it may lead to a safety hazard that may in turn endanger life or cause electrical shock to the operator.
3. The equipment shall not be installed in environmental conditions other than those mentioned in this manual.
4. Connector screw must be tightened after installation.

MECHANICAL DIMENSION

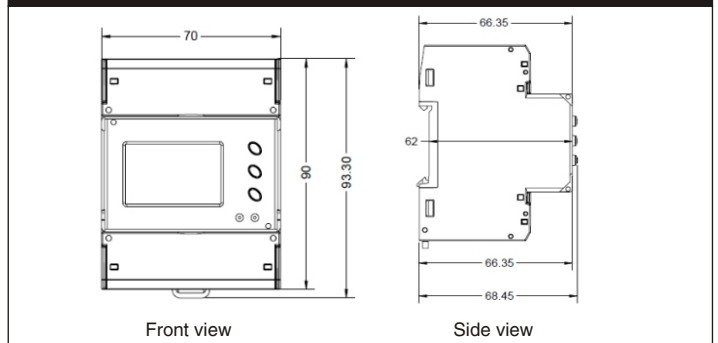

LUG DESCRIPTION

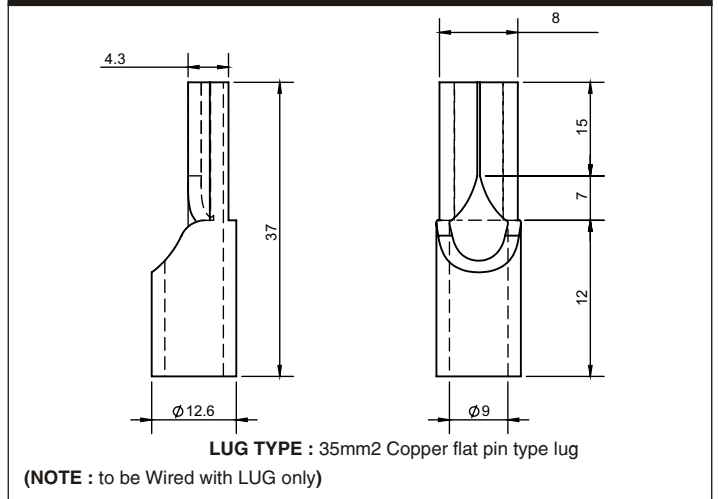

FRONT PANEL DESCRIPTION

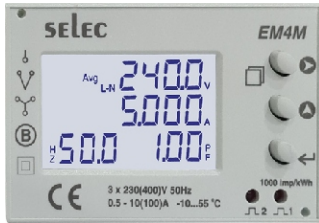

ONLINE PAGE DESCRIPTION

There are 2 dedicated keys labeled as (●) & (◀) Simply press these keys to read parameters. Units of corresponding parameter on display will automatically glow.

Key-1	●	Used for scrolling main pages
Key-2	◀	Used for scrolling sub pages
Key-3	◀	Used for display serial no.

Key Press	Parameter Key	Online page description
Online page description for 3P4W		
At Power ON	-	Display total import active energy of three phase
	Press (●) Key(1 st time)	Display total export active energy of three phase
	Press (●) Key(2 nd time)	Display total active energy of three phase DG (SRC2)
	Press (●) Key(3 rd time)	Display import & export active energy of 1 st phase
	Press (●) Key(4 th time)	Display import & export active energy of 2 nd phase
	Press (●) Key(5 th time)	Display import & export active energy of 3 rd phase
Press (●) key (1 st time)	-	Display total import reactive energy of three phase
	Press (●) Key(1 st time)	Display total export reactive energy of three phase
	Press (●) Key(2 nd time)	Display total reactive energy of three phase DG (SRC2)
	Press (●) Key(3 rd time)	Display import & export reactive energy of 1 st phase
	Press (●) Key(4 th time)	Display import & export reactive energy of 2 nd phase
Press (●) key (2 nd time)	-	Display total apparent energy of three phase MAINS (SRC1)
	Press (●) Key(1 st time)	Display total apparent energy of three phase DG (SRC2)
	Press (●) Key(2 nd time)	Display apparent energy of 1 st phase
	Press (●) Key(3 rd time)	Display apparent energy of 2 nd phase
	Press (●) Key(4 th time)	Display apparent energy of 3 rd phase
Press (●) key (3 rd time)	-	Displays line to neutral voltage of three phases
	Press (●) Key(1 st time)	Displays line to line voltage of three phases
	Press (●) Key(2 nd time)	Display Current of three phases
	Press (●) Key(3 rd time)	Display average of three phase line to neutral voltage, current, PF & frequency
	Press (●) Key(4 th time)	Display average of three phase line to line voltage, current, PF & Frequency
Press (●) key (4 th time)	-	Display Power factor of three phases & Frequency
	Press (●) Key(1 st time)	Display active power of three phases
	Press (●) Key(2 nd time)	Display reactive power of three phases
Press (●) key (5 th time)	Press (●) Key(3 rd time)	Display apparent power of three phases
	-	Display total active power
	Press (●) Key(1 st time)	Display total reactive power
	Press (●) Key(2 nd time)	Display total apparent power
	Press (●) Key(3 rd time)	Display max demand of active power
	Press (●) Key(4 th time)	Display max demand of reactive power
Press (●) Key(5 th time)	Display max demand of apparent power	

Key Press	Parameter Key	Online page description
Online page description for 3P3W		
At Power ON	-	Display total import active energy of three phase
	Press (●) Key(1 st time)	Display total export active energy of three phase
	Press (●) Key(2 nd time)	Display total active energy of three phase DG (SRC2)
Press (●) key (1 st time)	-	Display total import reactive energy of three phase
	Press (●) Key(1 st time)	Display total export reactive energy of three phase
Press (●) key (2 nd time)	Press (●) Key(2 nd time)	Display total reactive energy of three phase DG (SRC2)
	-	Display total Apparent energy of three phase MAINS (SRC1)
Press (●) key (3 rd time)	Press (●) Key(1 st time)	Display total Apparent energy of three phase DG (SRC2)
	-	Displays line to line voltage of three phases
Press (●) key (3 rd time)	Press (●) Key(1 st time)	Display Current of 1 st & 3 rd phase
	Press (●) Key(2 nd time)	Display average of three phase line to line voltage, current, PF & Frequency

Key Press	Parameter Key	Online page description
Online page description for 3P3W		
Press (●) key (4 th time)	-	Display total Active power
	Press (●) Key(1 st time)	Display total reactive power
	Press (●) Key(2 nd time)	Display total apparent power
	Press (●) Key(3 rd time)	Display max demand of active power
	Press (●) Key(4 th time)	Display max demand of reactive power
	Press (●) Key(5 th time)	Display max demand of apparent power

Key Press	Parameter Key	Online page description
Online page description for 1P2W		
At Power ON	-	Display import active energy of selected single phase
	Press (●) Key(1 st time)	Display export active energy of selected single phase
	Press (●) Key(2 nd time)	Display total Active energy DG (SRC2)
Press (●) key (1 st time)	-	Display import reactive energy of selected single phase
	Press (●) Key(1 st time)	Display export reactive energy of selected single phase
	Press (●) Key(2 nd time)	Display total reactive energy DG (SRC2)
Press (●) key (2 nd time)	-	Display selected single phase apparent energy MAINS (SRC1)
	Press (●) Key(1 st time)	Display selected single phase apparent energy DG (SRC2)
Press (●) key (3 rd time)	-	Display line to neutral voltage, current, PF & Frequency of selected single phase
	-	Display active power of selected single phases
Press (●) key (4 th time)	Press (●) Key(1 st time)	Display reactive power of selected single phases
	Press (●) Key(2 nd time)	Display apparent power of selected single phases
	Press (●) Key(3 rd time)	Display max demand of active power
	Press (●) Key(4 th time)	Display max demand of reactive power
	Press (●) Key(5 th time)	Display max demand of apparent power

AUTOMATIC / MANUAL / DEFAULT MODE DESCRIPTION

Press key ◀ for 3 seconds to toggle between Automatic, Manual and Default mode. **Note :** By default unit operates in manual mode. In automatic mode online pages scroll automatically at the rate of 6 seconds per page. In automatic mode when any key is pressed, unit temporarily switches to manual mode and the appropriate page is displayed.

SERIAL NUMBER DESCRIPTION

Press ◀ key to display 8 digit serial number only for 5sec at 2nd & 3rd row of display.

CONFIGURATION

There are two dedicated keys with symbol ● & ◀ Use these 2 keys to enter into configuration menu **Note :** The settings should be done by a professional, after going through this user manual and after having understood the application situation

For the configuration setting mode :

- Use (●) & ◀ key for 3 sec to enter and exit from configuration menu
- Use (●) key to increment the configuration parameter value
- Use (●) key to edit the value and shift the cursor to next digit, after last digit cursor goes back to 1st digit.
- Use ◀ key for enter & save the parameter value & go to the next page

Config. page	Function	Range or selection	Factory setting
1	Password	0000 to 9998	1000
2	Change Password	No / Yes	No
2.1	New Password	0000 to 9998	--
3	Selection Wiring	Bottom / Top	Bottom
4	Network Selection	3P4W, 3P3W 1P2W-P1, 1P2W-P2, 1P2W-P3	3P4W
5	Demand interval method	Sliding / Fixed	Sliding
6	Demand interval duration	1 to 30	15
7	Demand interval length	1 to 30 min	1
8	POP Type	Total kWh / IP kWh / EP kWh Total kVAh / IP kVAh / EP kVAh	Total kVAh
9	Pulse weight	1/10/100/1000	1000
10	Pulse duration	0.01 to 0.5 sec	0.1
11	Dual Source Setting	No / Yes	No
12	Slave Id	1 to 255	1
13	Baud Rate	2400,4800, 9600,19200 & 38400 bps	9600
14	Parity	None, Odd, Even	None
15	Stop Bit	1 or 2	1
16	Endianness	MSRF/LSRF	MSRF
17	Backlight	0 to 7200	0
18	Factory default	No / Yes	No
19	Reset Energy and max Dmd	No / Yes	No
19.1	Password	0001 to 9999	1001
19.2	Reset Energy and max Dmd	SRC1/SRC2	SRC1
19.3	Reset kWh	No / Yes	No
19.4	Reset kVAh	No / Yes	No
19.5	Reset kVAh	No / Yes	No
19.6	Reset max demand	No / Yes	No

Note: 1) For resetting energy parameter user will be promoted for password. If correct password is entered. User will be able to reset all energy parameters. This password is equal to existing configuration entry password plus 1.

2) DG pages only visible when Dual Source setting is YES from configuration

NETWORK SELECTION AND WIRING INPUT	
Network selection in configuration mode	Wiring
3P4W	3P4W, 2P3W
3P3W	3P3W
1P2W	1P2W-P1 / 1P2W-P2 / 1P2W-P3

PULSE OUTPUT DESCRIPTION			
Pulse output	Type	Description	Pulse Width
POP1	Fixed 1000 Pulses	Per kWh	0.01 to 0.5sec
POP2	Configurable 1/10/100/1000 Pulses	Per kWh - Total/IMP/EXP Per kVArh - Total/IMP/EXP	0.01 to 0.5sec

Note: Above 30A current pulse duration should be set to 0.01 sec

MODBUS REGISTER ADDRESS LIST	
Readable parameters for Communication Model Only : [Length (Register) : 2 ; Data Structure : Float]	

Address	Hex Address	Parameter
30000	0x00	Voltage V1N
30002	0x02	Voltage V2N
30004	0x04	Voltage V3N
30006	0x06	Average Voltage LN
30008	0x08	Voltage V12
30010	0x0A	Voltage V23
30012	0x0C	Voltage V31
30014	0x0E	Average Voltage LL
30016	0x10	Current I1
30018	0x12	Current I2
30020	0x14	Current I3
30022	0x16	Average Current
30024	0x18	kW1
30026	0x1A	kW2
30028	0x1C	kW3
30030	0x1E	kVAr1
30032	0x20	kVAr2
30034	0x22	kVAr3
30036	0x24	kVA1
30038	0x26	kVA2
30040	0x28	kVA3
30042	0x2A	Total kW
30044	0x2C	Total kVAr
30046	0x2E	Total kVA
30048	0x30	PF1
30050	0x32	PF2
30052	0x34	PF3
30054	0x36	Average PF
30056	0x38	Frequency
30058	0x3A	Total Net kVAh (MAINS)
30060	0x3C	Total Net kVAh (MAINS)
30062	0x3E	Total Net kVAh (MAINS)
30064	0x40	Total Net kWh (DG)
30066	0x42	Total Net kVArh (DG)
30068	0x44	Total Net kVAh (DG)
30070	0x46	Max DMD Active Power
30072	0x48	Max DMD Reactive Power
30074	0x4A	Max DMD Apparent Power
30076	0x4C	kWh1 – Import
30078	0x4E	kWh2 – Import
30080	0x50	kWh3 – Import
30082	0x52	kWh1 – Export
30084	0x54	kWh2 – Export
30086	0x56	kWh3 – Export
30088	0x58	Total kWh – Import
30090	0x5A	Total kWh – Export
30092	0x5C	kVArh1 – Import
30094	0x5E	kVArh2 – Import
30096	0x60	kVArh3 – Import
30098	0x62	kVArh1 – Export
30100	0x64	kVArh2 – Export
30102	0x66	kVArh3 – Export
30104	0x68	Total kVArh – Import
30106	0x6A	Total kVArh – Export
30108	0x6C	kVAh-1
30110	0x6E	kVAh-2
30112	0x70	kVAh-3
30684	0x2AC	Serial No. (Data structure : Hex)
30710	0x2C6	DG Sensing
		1 : Pass
		0 : Fail

Energy rollover counter addresses : Energy rollover counter will increment when energy is roll over from 99999.99 to 0. [Data Structure: Integer]

Address	Parameter	Address	Parameter
31149	Import kWh1	31155	Total Import kWh
31150	Import kWh2	31156	Total Export kWh
31151	Import kWh3	31157	Total kWh (MAINS)

Address	Parameter	Address	Parameter
31152	Export kWh1	31158	Import kVArh1
31153	Export kWh2	31159	Import kVArh2
31154	Export kWh3	31160	Import kVArh3
31161	Export kVArh1	31168	kVAh2
31162	Export kVArh2	31169	kVAh3
31163	Export kVArh3	31170	Total kVAh (MAINS)
31164	Total Import kVArh	31171	Total kWh (DG)
31165	Total Export kVArh	31172	Total kVArh (DG)
31166	Total kVArh (MAINS)	31173	Total kVAh (DG)
31167	kVAh1		

READABLE / WRITABLE PARAMETERS FOR COMMUNICATION MODEL ONLY :[DATA STRUCTURE :INTEGER]

Address	Parameter	Range		Length (Register)
		Min Value	Max Value	
40000	Password	0	9998	1
		Min Value	Max Value	
40001	Slave id	1	255	1
		Value	Meaning	
40004	N/W Selection	0	3P4W	1
		1	3P3W	
		2	1P2W-P1	
		3	1P2W-P2	
		4	1P2W-P3	
		Value	Meaning	
40005	Demand Interval Method	0	Sliding	1
		1	Fixed	
		Min Value	Max Value	
40006	Demand Interval Duration	1	30	1
40007	Demand Interval Length	1	30	1
		Value	Meaning	
40008	POP	0	Total kWh	1
		1	Total kVArh	
		2	IP kWh	
		3	EP kWh	
		4	IP kVArh	
		Value	Meaning	
40009	Pulse Weight	0	1	1
		1	10	
		2	100	
		3	1000	
		Value	Meaning	
40010	Pulse Duration	1	0.01	1
		2	0.05	
		3	0.1	
		4	0.2	
		5	0.3	
		6	0.4	
		7	0.5	
		Value	Meaning	
40011	Dual source	0	No	1
		1	Yes	
40012	Baud rate (bps)	0	2400	1
		1	4800	
		2	9600	
		3	19200	
40013	Parity	0	None	1
		1	odd	
		2	Even	
40014	Stop bit	1	1	1
		2	2	
		Min Value	Max Value	
40015	Backlight OFF (sec)	0	7200	1
		Value	Meaning	
40016	Factory default	1	Set to factory default	1
40017	Reset Max Demand	1	Reset Max Demand	1
40040	Reset Mains kWh	1	Reset active Mains energy	1
40041	Reset Mains kVArh	1	Reset reactive mains energy	1
40042	Reset Mains kVAh	1	Reset apperant mains energy	1

40043	Reset DG kWh	1	Reset active DG energy	1
40044	Reset DG kVarh	1	Reset reactive DG energy	1
40045	Reset DG kVAh	1	Reset apperant DG energy	1
		Value	Meaning	
40046	Change Wiring Selection	0	Bottom	1
		1	Top	
40070	Endianness Selection	0	Mid Little Endian (CDAB)	1
		1	Big Endian (ABCD)	

POWER FACTOR SIGN CONVENTION

Power Factor sign convention (PF sign) can be positive or negative, and is defined by the conventions used by the IEC standard.

PF sign correlates with the direction of real power (kW) flow.

- Quadrant 1 and 4: Positive real power (+kW).
The PF sign is positive(+).
- Quadrant 2 and 3: Negative real power (-kW).
The PF sign is negative(-).

EXAMPLE TO READ DATA FROM INPUT REGISTER

Data format: Big Endian (MSRF)

If Total Active Energy = 1234.12kWh Start Address : 30058, No. Of register : 02
Hexadecimal Equivalent of 1234.12 is 0x449A43D7

Data stored at 30058 is LSB : $\frac{A}{44} \frac{B}{9A}$

Data Stored at 30059 is MSB : $\frac{C}{43} \frac{D}{D7}$

Data Format to be followed is A-B-C-D

Data format: Mid Little Endian(LSRF)

If Total Active Energy = 1234.12kWh Start Address : 30058, No. Of register : 02
Hexadecimal Equivalent of 1234.12 is 0x449A43D7

Data stored at 30058 is LSB : $\frac{C}{43} \frac{D}{D7}$

Data Stored at 30059 is MSB : $\frac{A}{44} \frac{B}{9A}$

Data Format to be followed is C-D-A-B

TYPICAL WIRING DIAGRAM

3 Phase - 4 Wire

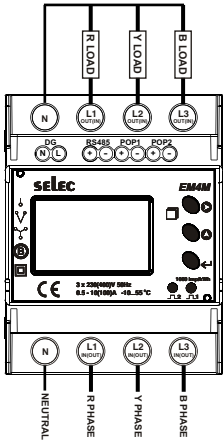

1 Phase - 2 Wire - R

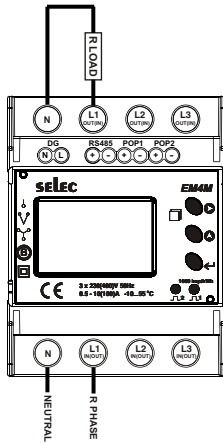

3 Phase - 3 Wire (Star Load)

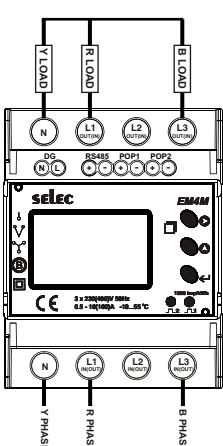

3 Phase - 3 Wire (Delta Load)

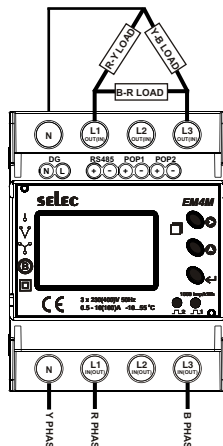

CONNECTION DIAGRAM FOR COMMUNICATION

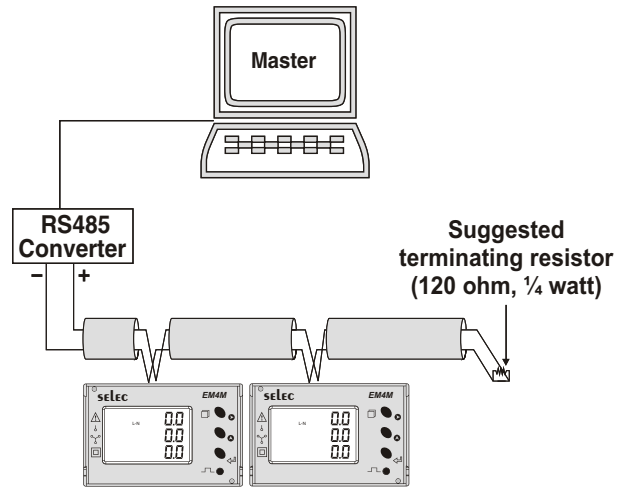

Contact sales for PC based monitoring software to communicate with the meters.

TYPICAL WIRING DIAGRAM

1 Phase - 2 Wire - Y

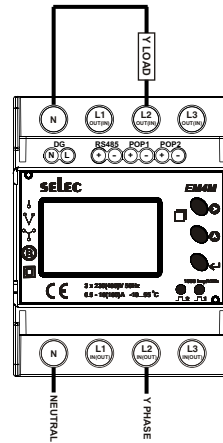

1 Phase - 2 Wire - B

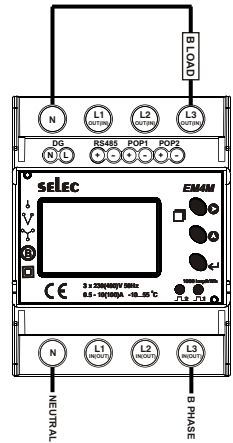

2 Phase - 3 Wire

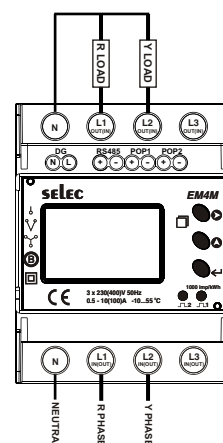

TERMINAL CONNECTION

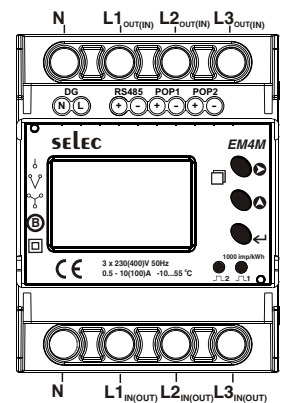

Note: This meter can be supplied from the Top or the Bottom. Default is Bottom.

(Specifications are subject to change, since development is a continuous process.)

Selec Controls Pvt. Ltd.

Factory Address : EL-27/1, Electronic Zone, TTC Industrial Area, MIDC, Mahape, Navi Mumbai - 400 710, India.

Website : www.selec.com

For Sales & Support,

Tel. No. : +91-22-41418468 / 452

Mob. No. : +91-9136977315, Email : sales@selec.com

For Service,

Tel. No. : +91-7498077172 / +91-7400069545

Email : service@selec.com