



96 x 96mm

Features :

- 3Ø True RMS (Voltage, Current)
- 3Ø Power (Active, Reactive, Apparent), Energy (Active, Reactive, Apparent)
- Plug-n-Wire, RJ45 Connector Current Input
- Programmable CT Primary, PT Primary / Secondary
- Modbus RTU Communication (RS485)
- Pulse Output
- Max / Min Demand of Power
- % THD upto 31st level for Voltage and Current

Certification : **CE**

Display Specifications

| | |
|----------|--|
| Display | 4 rows, LCD with Backlight |
| Digits | 4 (Lowest 8 digits for energy display) |
| Bargraph | For Current Representation |

Input Specifications

| | |
|-----------------------|--|
| Electrical Connection | 3Ø - 4 wire, 1Ø - 2 wire |
| Input Voltage Range | 100 to 240V AC (L - N) 173 to 415V AC (L - L) |
| Frequency | 45 to 65Hz |
| Display Scrolling | Automatic / Manual |
| Power Consumption | 8VA max |
| Display Reset | Programmable (For energy) |
| Resolution | For energy : 0.1k, 1k (depending upon CT rating) For Power, Voltage, Current : Auto Resolution For Power Factor : 0.001 |
| Accuracy | Voltage (L - N / L - L) : ±0.5% of F.S. Current : ±0.5% of F.S. Power Factor : ±0.01 Frequency : ±0.1% (For V>20V L - N, V>35V L - L) Power (kW, kVA, kVA): 1% Energy (Active, Reactive, Apparent) : 1% |
| Memory Retention | 10 years (For energy) |
| Measuring Parameters | Voltage (L - L / L - N) (Individual / Average), Current (Individual / Average), Frequency, Power Factor (Individual / Average), Active, Reactive & Apparent Power (Individual / Total), Active, Reactive & Apparent Energy [Phase Wise (Import / Export) & Total (Import / Export)], Demand (Min / Max Active Power, Min / Max Reactive Power, Max Apparent Power), %THD individual for Voltage & Current upto 31 st level |

Output Specifications

| | |
|--------------------------------------|---|
| Pulse Output | Voltage Range : External 24V DC max Current Capacity : 100mA max Pulse Width : Selectable between 0.1 to 2 sec. |
| Communication Interface and Protocol | RS485 and MODBUS RTU |
| Communication Address | 1 to 255 |
| Transmission Mode | Half duplex |
| Transmission Distance | 500 meter maximum |
| Transmission Speed | 300, 600, 1200, 2400, 4800, 9600, 19200 (in bps) |
| Parity | None, Odd, Even |
| Stop Bits | 1 or 2 |
| Response Time | 100ms (max and independent of baud rate) |

Auxiliary Supply Specifications

| | |
|----------------|--|
| Supply Voltage | 60 to 300VAC, 50 / 60Hz, Self Supplied (V1, N) |
|----------------|--|

Settable Parameters

| | |
|--------------|--|
| CT Primary | 5A to 10kA (Programmable for any value) |
| CT Secondary | 330mV |
| PT Primary | 100V to 500kV (Programmable for any value) |
| PT Secondary | 173V to 415V AC (Programmable for any value) |

Environmental Specifications

| | |
|-----------------------------|--|
| Temperature | Operating Temperature : 0° to 50° C Storage Temperature : -20° to 75° C |
| Humidity (non - condensing) | Upto 85% RH |

Mechanical Specifications

| | |
|----------|--------|
| Mounting | Panel |
| Weight | 230gms |

Dimensions

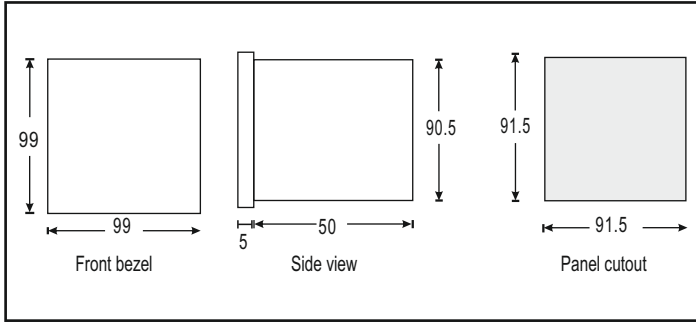

Terminal Connection

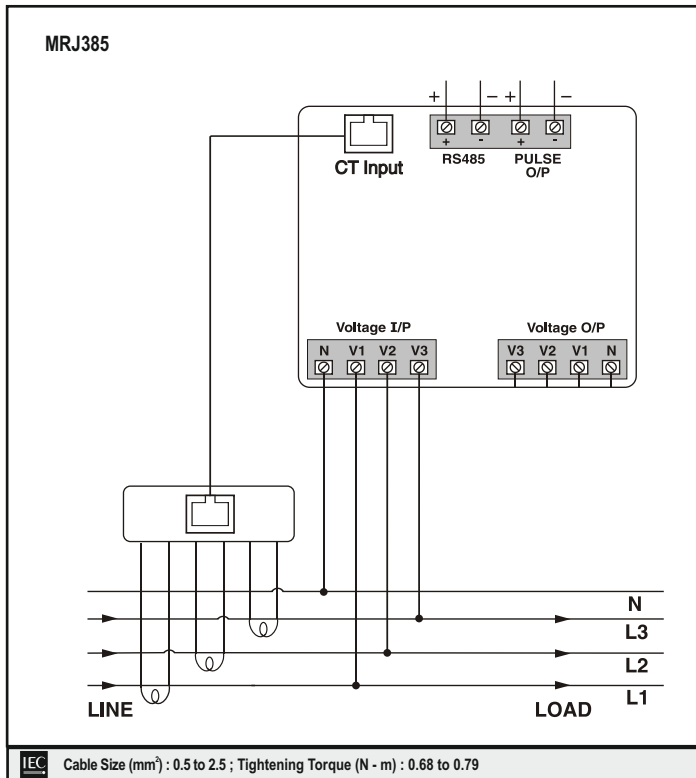

Compliance

| Applicable EMI / EMC Standards | | |
|----------------------------------|--------------------|---|
| Product Standard : IEC 61326 - 1 | | |
| Category | | Standards Compliance |
| ESD Immunity | IEC 61000 - 4 - 2 | Level IV (Air Discharge : 15kV), (Contact Discharge : -8kV) |
| Surge Immunity | IEC 61000 - 4 - 5 | + / - 2kV Common Mode, (Line to Ground) + / - 1kV Differential Mode, (Line to Line) |
| Radiated Susceptibility | IEC 61000 - 4 - 3 | Level III, 80 to 1000MHz (10V / m) Level II, 1.4GHz to 2GHz (3V / m) Level I, 2GHz to 2.7GHz (1V / m) |
| Conducted Susceptibility | IEC 61000 - 4 - 6 | Level II (3V / m) |
| Voltage Dips and Interruptions | IEC 61000 - 4 - 11 | Dips : 0% residual voltage / 1 cycle (Criteria B), 40% residual voltage / 10 cycles 50Hz / 12 cycles 60Hz (Criteria C) 70% residual voltage / 25 cycles 50Hz / 30 cycles 60Hz (Criteria C) Interruptions : 0% residual voltage / 250 cycles 50Hz / 300 cycles 60Hz (Criteria C) |
| Conducted Emission | CISPR - 11 | |
| Radiated Emission | CISPR - 11 | |
| Electrical Fast Transient | IEC 61000 - 4 - 4 | Level III (2kV) |

Ordering Information

| Product Code | Supply Voltage | Output | | Certification |
|--------------|--|--------------|---------------|---------------|
| MRJ385-G-PNW | Self Supplied (V1, N) 60 to 300V AC | Pulse Output | Comm. (RS485) | CE |