

# OPERATING INSTRUCTIONS

## XT56-N/564-N/264/364

Please maintain these instructions and review them prior to using the unit:

### ⚠ Warning:

1. This unit is panel mounted type with its output terminals getting connected to the host equipment. Such equipment shall also comply with basic EMI/EMC and safety requirements like BS EN 61326-1 and BS EN 61010 respectively.
2. To avoid electric shock, power supply of the unit should be kept off while wiring. Wiring should be done strictly as per the terminal layout, given in the manual.
3. Use lugged terminals to meet M3 screws.
4. The unit does not have a built-in fuse. External fuse with a rating of 275VAC/1A is recommended.

### ⚠ Caution:

1. This unit is not intended for outdoor use.
2. The power connection cable must have a cross-section of atleast 1mm<sup>2</sup> and insulation capacity of atleast 1.5kV.
3. The output connections must not be loaded beyond the specified values/range.
4. Avoid inflow of dust and contact of conductive material with the internal circuitry of the unit.
5. The unit must not operate in presence of heating sources, caustic vapors, oil, steam, vibration or impact etc.
6. Use clean soft cloth for cleaning. Do not use any organic solvents like Isopropyl alcohol. Care must be taken to avoid entry of water into the circuitry through the ventilation holes.

## SPECIFICATIONS

### DISPLAY

**XT56-N/564-N:** 3 digit, 0.3" Height, Red LED.  
**XT264-2/364-2:** 2 digit, 0.5" Height, Red LED.  
**XT264-3/364-3:** 3 digit, 0.5" Height, Red LED.

### SET POINT

Single set point.

### SUPPLY (FACTORY SET)

90 to 270V AC/DC, AC: 50 or 60 Hz.  
 24V AC/DC

### DELAY MODES

On delay / Interval.

### TIME RANGES

**XT56-N/564-N/264-3/364-3:**  
 9.99, 99.9, 999 sec, 99.9, 999 min, 99.9 hr.  
**XT264-2/364-2:** 9.9, 99sec, 9.9, 99min, 9.9hr.

### TIME SETTING

By push wheel switches.

### ACCURACY

**XT56-N:** ±0.05% or 50 msec.  
 (whichever is greater)  
**XT564-N/264/364:** ±0.5% or 50 msec.  
 (whichever is greater)

### START INPUT

Pulse Start.

### RESET

- 1) Front panel reset.
- 2) Remote reset.
- 3) On power interruption.

### RESET TIME

Less than 100 msec.

### COUNT DIRECTION

Down.

### LED INDICATION

Relay status.

### OUTPUT

**XT56-N/264/364 : 2NO/NC**  
**XT564-N: 1NO/NC.**

### RELAY RATING

5A @ 230VAC/24VDC

### MOUNTING

Panel mounting.

### HOUSING

**CE marked products:** Flame retardant plastic.  
**Non CE products:** ABS plastic.

### TEMPERATURE

**Operating:** 0 to 50°C  
**Storage:** -5 to 55°C.

## HUMIDITY

95% RH.

## WEIGHT (gms)

**XT56-N:** 170, **XT564-N:** 200,  
**XT264:** 325, **XT364:** 350

## PRODUCT CODE

MODELS	DIGITS	BEZEL SIZE(mm)
XT56-N	3	48 x 48
XT564-N	3	48 x 48
XT264-2	2	72 x 72
XT264-3	3	72 x 72
XT364-2	2	96 x 96
XT364-3	3	96 x 96

## OVERALL DIMENSIONS (All dimensions in mm)

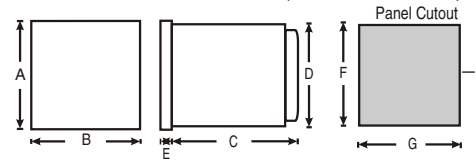

DIM MODELS	Panel Cutout						
	A	B	C	D	E	F	G
XT56-N	48	48	100	45	7	46	46
XT564-N	48	48	100	45	7	46	46
XT264	72	72	115	68	10	69	69
XT364	96	96	70	90	10	92	92

## TIMING DIAGRAM

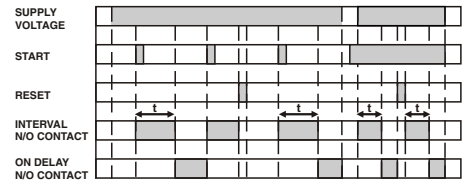

t = Set delay time

## TERMINAL CONNECTIONS

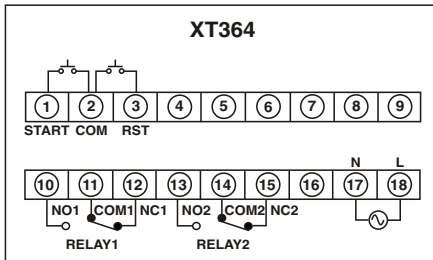
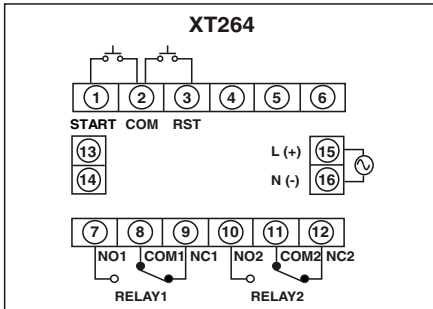
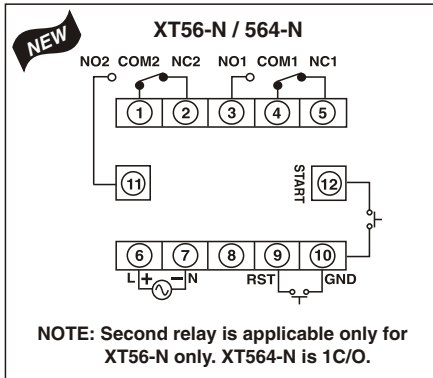

TERMINAL DESCRIPTION	TERMINALS FOR			
	XT56-N	XT564-N	XT264	XT364
L (Live)	6	6	15	18
N (Neutral)	7	7	16	17
COM of relay 1	4	4	8	11
NO of relay 1	3	3	7	10
NC of relay 1	5	5	9	12
COM of relay 2	1	–	11	14
NO of relay 2	11	–	10	13
NC of relay 2	2	–	12	15
START input	12 - 10	12	1 - 2	1 - 2
RESET input	9 - 10	9	3 - 2	3 - 2
GND (COM)	10	10	2	2

## LOAD CONNECTIONS

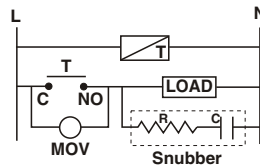

- 1) Snubber Part No.: APRC - 01.
  - 2) MOV Part No.: AP-MOV - 03.
- Note: For inductive loads, use of snubber and MOV, as shown above, is recommended.

## DIP SWITCH SETTINGS FOR MODE

MODE (2 / 3 digit)	SW 1
ON DELAY	OFF
INTERVAL	ON

## DIP SWITCH SETTINGS FOR TIME RANGE

RANGE		SW2	SW3	SW4
2 digit	3 digit			
9.9 sec	9.99 sec	OFF	OFF	OFF
99 sec	99.9 sec	OFF	OFF	ON
9.9 min	999 sec	OFF	ON	OFF
99 min	99.9 min	OFF	ON	ON
9.9 hr	999 min	ON	OFF	OFF
--	99.9 hr	ON	OFF	ON

## DIP SWITCH SETTING EXAMPLE

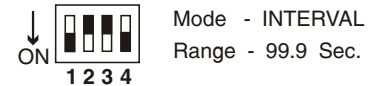

**NOTE :** DIP switch for range and mode settings is on the side of the Instrument.

(Specifications subject to change as development is a continuous process).

## Selec Controls Pvt. Ltd., India.

(Formerly Selectron Process Controls Pvt. Ltd.)  
Tel: 91-22-28476443/1882, Fax: 91-22-28471733,  
Toll free: 1800 227 353, Web.: www.selec.com  
E-mail: sales@selec.com.