



DIN 35mm

Features

- 1Ø - 2 Wire, 3Ø - 3 Wire, 3Ø - 4 Wire input
- Monitors Under voltage, Over voltage, Under frequency, Over frequency, Phase asymmetry, Phase failure, Phase sequence and Neutral loss in (3Ø - 4W) system
- True RMS measurement
- Power ON delay, Trip time delay and Recovery time delay
- Adjustable switching hysteresis
- Two relays with NO or NC operation selectable

Certification :

Display specifications

Type	Digital
Display	Liquid Crystal Display
No. of LED	3
No. of push button	3

LED indication chart

Condition	POWER LED	'R1' LED	'R2' LED
No fault	ON	OFF	OFF
Trip (Relay1)	ON	ON	OFF
Trip (Relay2)	ON	OFF	ON
Trip (If Programming for both relay)	ON	ON	ON

Input specifications

Functions	
Measurements	Under voltage, Over voltage, Under frequency, Over frequency, Phase asymmetry, Phase failure, Phase sequence and Neutral loss Note: In 3P4W, when neutral is absent all L-N voltage are zero
Time setting	Power on delay, Trip time delay and Recovery time delay, Response time
Alarm indications	Trip
Latching	Fail safe & shunt trip mode (selectable)
Reset	Auto / Manual
Measuring range	3Ø - 3 wire (L-L) : 280 to 600V AC 3Ø - 4 wire (L-N) : 160 to 300V AC 1Ø - 2 wire (L1-N1) : 160 to 300V AC
Trip settings	
Under voltage	280 to 600V AC (L-L) [for 3Ø - 3 wire] 160 to 300V AC (L-N) [for 3Ø - 4 wire] 160 to 300V AC (L1-N1) [for 1Ø - 2 wire]
Over voltage	280 to 600V AC (L-L) [for 3Ø - 3 wire] 160 to 300V AC (L-N) [for 3Ø - 4 wire] 160 to 300V AC (L1-N1) [for 1Ø - 2 wire]
Under frequency	45 - 65Hz
Over frequency	45 - 65Hz
Phase asymmetry	5 - 99%
Hysteresis	
Voltage	1.0V -99.9V
Frequency	0.2 - 2.0Hz
Asymmetry	2.0 - 20%

Input specifications

Resolution	
Voltage	1V
Frequency	0.1Hz
Accuracy	
Voltage	±1% of full range
Frequency	±0.3Hz
Time	±5% of setting, ±250ms

Output specifications

Relay output	2 SPDT Relays (1 C/O)
Relay rating	NO (5A @ 250V AC) , NC (3A @ 250V AC)

Environmental specifications

Operating temperature	0 to 55°C
Storage temperature	-20 to 70°C
Humidity (Non condensing)	Up to 95% RH
Degree of protection	IP20

Mechanical specifications

Dimension (in mm)	35 x 90 x 70.5 (W x H x D)
Weight (unpacked)	135 gms
Mounting	Din Rail
Terminal torque & capacity	0.5 NM
Enclosure	LEXAN N923(PC)

Dimensions (All are in mm)

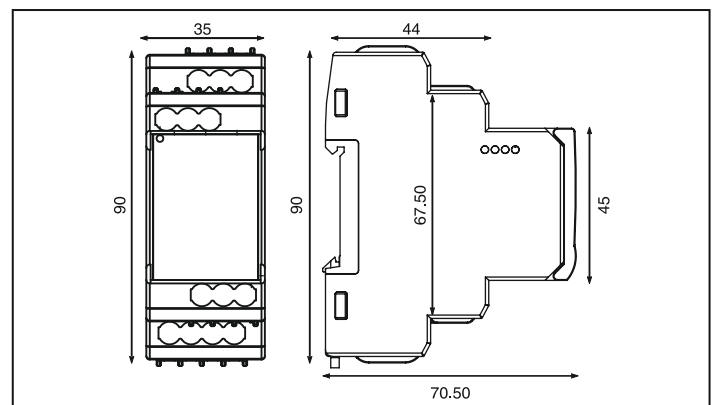

Terminal connection

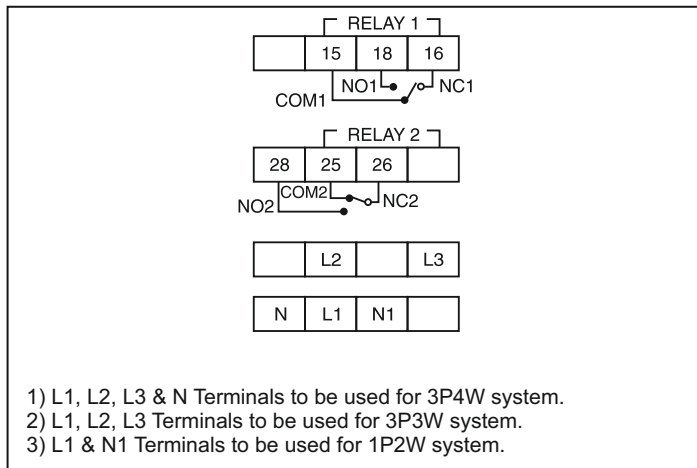

Environmental

Product standard : IEC 60255-1/IEC 60947-5-1	
Safety test standard : IEC 61010-1	1.High voltage test 2.Impulse voltage withstand test 3.Resistance to heat test 4.Single fault test 5.Temperature rise test

Ordering information

Product code	Operating range	Certification
900VPR-2-280/600V-CE-RoHS	280 to 600V AC	CE

Compliance

Applicable EMC standards	
Product standard - IEC 60255-1/IEC 60947-5-1	
Category	Reference standards
Electrostatic discharge	IEC 61000-4-2
Electrical fast transient / Burst	IEC 61000-4-4
Electromagnetic field	IEC 61000-4-3
Surge	IEC 61000-4-5
Conducted RF	IEC 61000-4-6
Rated power frequency	IEC 61000-4-8
Voltage dip / Short interruptions	IEC 61000-4-11
Conducted emissions	CISPR-22
Radiated emissions	CISPR-11