



96 x 96

SPECIFICATIONS

DISPLAY

- 3 Row of 4 Digits
- 7 Segment LED Display 0.49 inch Height Digit
- Integrated with parameter Units

WIRING INPUT

- 3 Ø - 4 wire, 3 Ø - 3 wire and
- 1 Ø - 2 wire (R/Y/B Programmable)

AUXILIARY SUPPLY

40V-300V AC/DC

RATED INPUT VOLTAGE

- 11 to 300V AC (L-N); 19 to 519V AC (L-L)
- Installation Category III (600V)

FREQUENCY RANGE

50-60 Hz

RATED INPUT CURRENT

Nominal 5A AC (Min-20mA, Max-6A)

BURDEN

0.5VA@5A per phase

CT PRIMARY

1A / 5A to 10,000A (Programmable for any value)

Note : 1A to 10,000A if CT secondary is 1 else
5A to 10,000A

CT SECONDARY

1A or 5A (programmable)

PT PRIMARY

100V to 500kV (Programmable for any value)

PT SECONDARY

100 to 500V (Programmable for any value)

DISPLAY UPDATE TIME

1 sec. for all parameters

DISPLAY SCROLLING

Auto / Manual / Default

POWER CONSUMPTION

Less than 5VA

ENVIRONMENTAL CONDITIONS

- Indoor use
- Altitude of up to 2000 meters
- Pollution degree II

Temperature : Operating : -10°C to 55°C

Storage : -20°C to 75°C

Humidity : Up to 85% non-condensing

MOUNTING : Panel mounting

WEIGHT : MFM376-C-CE : 200gms
MFM376-CE : 200gms

OUTPUT

Pulse Output : Voltage range : External 24V DC max.
Current capacity : 100 mA max

Pulse Width : 100ms ± 5ms.

ORDER CODE INFORMATION

Product	Supply	Certification	
		CE	UL LISTED
MFM376-C-CE	40V-300V AC/DC,50/60Hz	■	—
MFM376-CE	40V-300V AC/DC,50/60Hz	■	—

Installation Category III

SERIAL COMMUNICATION

Interface standard and protocol	RS485 and MODBUS RTU
Communication address	1 to 255
Transmission mode	Half duplex
Data types	Float and Integer
Transmission distance	500m maximum
Transmission Speed	300, 600,1200, 2400, 4800, 9600,19200 (in bps)
Parity	None, Odd, Even
Stop bits	1 or 2

ACCURACY

Measurement	Accuracy
Voltage V_{L-N}	±0.5% of Full scale
Voltage V_{L-L}	±0.5% of Full scale
Current	±0.5% of Full scale
Frequency	±0.1% For L-N Voltage >20V, For L-L Voltage >35V
Active Power	1%
Apparent power	1%
Reactive Power	1%
Power Factor	±0.01
Active Energy	Class 1
Reactive Energy	Class 2
Apparent Energy	Class 1

RESOLUTION :

PT Ratio x CT Ratio	kWh / kVAh / kVArh	Pulse	INT
≤40	0.01K	0.01K	0.001K
≤400	0.1K	0.1K	0.01K
≤4000	1K	1K	0.1K
≤40000	0.01M	0.1M	0.01M
≤400000	0.1M	0.1M	0.01M
≥400000	1M	0.1M	0.01M

Note : a) For voltage, current and power resolution is automatically adjusted
b) For power factor resolution is 0.001
c) INT LED blinks indicating accumulation of energy, if load is connected on any one phase of 3 Phase.

SAFETY PRECAUTIONS

All safety related codifications, symbols and Instructions that appear in this operating manual or on the equipment must be strictly followed to ensure the safety of the operating personnel as well as the instrument.

If the equipment is not used in a manner specified by the manufacturer it might impair the protection provided by the equipment.

- Do not use the equipment if there is any mechanical damage.
- Ensure that the equipment is supplied with correct voltage.

CAUTION :

1. Read complete instructions prior to installation and operation of the unit.
2. Risk of electric shock.
3. The equipment in its installed state must not come in close proximity to any heating sources, oils, steam, caustic vapors or other unwanted process by products.

WIRING GUIDELINES

WARNING :

1. To prevent the risk of electric shock, power supply to the equipment must be kept OFF while doing the wiring arrangement.
2. Wiring shall be done strictly according to the terminal layout. Confirm that all connections are correct.
3. Use lugged terminals.
4. To reduce electromagnetic interference use of wires with adequate ratings and twists of the same in equal size shall be made with shortest connections.
5. Layout of connecting cables shall be away from any internal EMI source.
6. Cable used for connection to power source, must have a cross section of 0.5mm² to 2.5mm² (20 to 14AWG ; 75°C(min)). These wires shall have current carrying capacity of 6A.
7. Copper cable should be used (Stranded or Single core cable).
8. Before attempting work on device, ensure absence of voltages using appropriate voltage detection device.

INSTALLATION GUIDELINES

CAUTION :

1. This equipment, being built-in-type, normally becomes a part of main control panel and in such case the terminals do not remain accessible to the end user after installation and internal wiring.
2. Conductors must not come in contact with the internal circuitry of the equipment or else it may lead to a safety hazard that may in turn endanger life or cause electrical shock to the operator.
3. Circuit breaker or mains switch must be installed between power source and supply terminals to facilitate power 'ON' or 'OFF' function. However this switch or breaker must be installed in a convenient position normally accessible to the operator.
4. Before disconnecting the secondary of the external current transformer from the equipment, make sure that the current transformer is short circuited to avoid risk of electrical shock and injury.
5. The equipment shall not be installed in environmental conditions other than those mentioned in this manual.
6. The equipment does not have a built-in-type fuse. Installation of external fuse of rating 275V AC / 0.5Amp for electrical circuitry / battery is highly recommended.

MOUNTING INSTRUCTION

1. Prepare the panel cutout with proper dimension as shown below & Push the meter with gasket into the panel cutout.

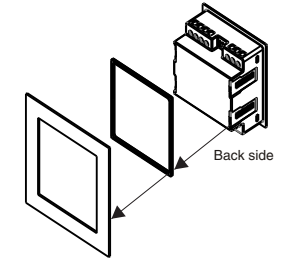

2. Fit clamps on both side in diagonally opposite location for optimum fitting.

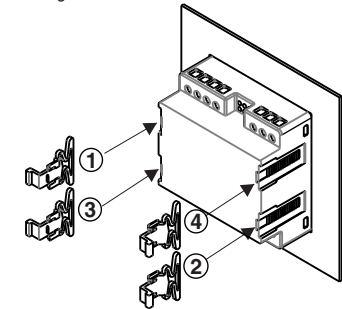

3. Slide all 4 clamps towards the panel evenly till the lowest possible tooth of the clamp is engaged. Ensure the meter is properly tightened.

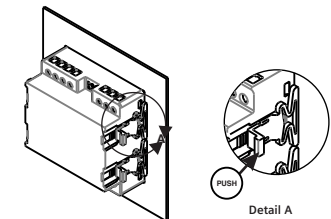

DEMOUNTING INSTRUCTION

1. Pull the arm of the sliding clamp in outward direction (opposite to meter) and drag the sliding clamps away

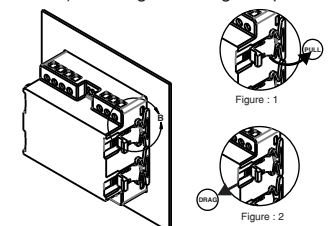

2. Push the meter from the back side of the panel window.

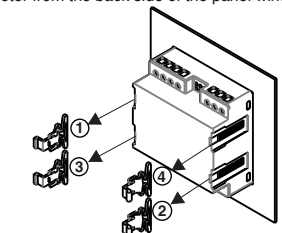

3. Remove unit from the panel.

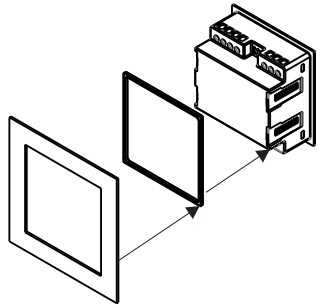

MECHANICAL INSTALLATION

For installing the meter

1. Prepare the panel cutout with proper dimensions as shown below.
2. Push the meter into the panel cutout. Secure the meter in its place by fitting the clamp on the rear side. fit clamps on both sides in diagonally opposite location for optimum fitting.
3. For proper sealing, tighten the screws evenly with required torque.

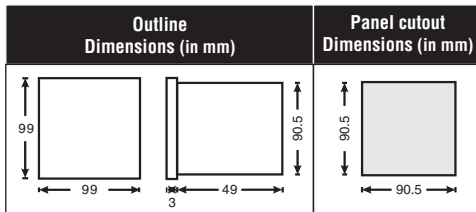

MAINTENANCE

1. The equipment should be cleaned regularly to avoid blockage of ventilating parts.
2. Clean the equipment with a clean dry or damp cloth. Do not use any cleaning agent other than water.

TERMINAL CONNECTIONS

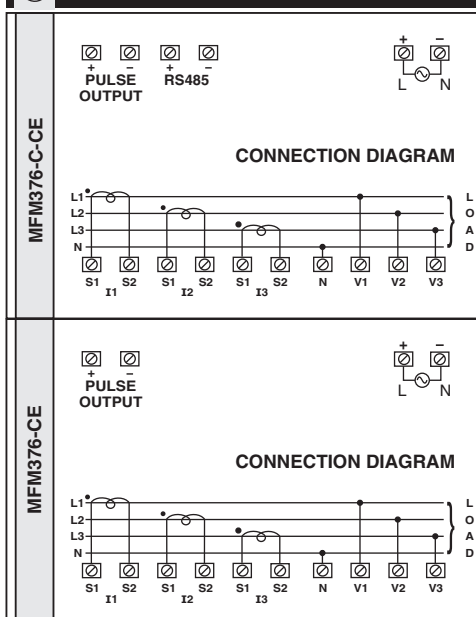

FRONT PANEL DESCRIPTION



ONLINE PAGE DESCRIPTION

There are three dedicated keys labelled as Δ, ♥ and ○. Use these 3 keys to read parameters. Simply press these keys to read the parameters. Units of corresponding parameters on display will glow automatically. Use ♥ key to go back to previous page in sub page.

MFM376-C-CE / MFM376-CE		
KEY PRESS	ONLINE PAGE DESCRIPTION	
—	1st screen	Displays three phase line to neutral voltage.
Press "Δ"	2nd screen	Displays three phase line to line voltage.
	3rd screen	Displays total percentage harmonics of line to neutral voltage of three phase.
	4th screen	Displays total percentage harmonics of line to line voltage of three phase.
	5th screen	Displays three phase Maximum line to neutral voltage.
	6th screen	Displays three phase Maximum line to line voltage.
	Press "○"	1st screen
2nd screen		Displays total percentage harmonics of current of three phase
3rd screen		Displays active, reactive and apparent power of first phase.
4th screen		Displays active, reactive and apparent power of second phase.
5th screen		Displays active, reactive and apparent power of third phase.
6th screen		Displays total active, reactive and apparent power of three phase.
7th screen		Displays active, reactive and apparent maximum power demand of three phase.
8th screen		Displays active and reactive minimum power demand of three phase.
Note : 1) For 3 phase 3 wire, only second, forth and sixth screen will be available. 2) For 1 phase 2 Wire, only first, third and fifth screen of selected phase will be available.		
Press "○"	1st screen	Displays three phase Maximum current.
	2nd screen	Displays three phase power factor.

KEY PRESS	ONLINE PAGE DESCRIPTION	
Press "○"	3rd screen	Displays three phase phase angle.
	4th screen	Displays three phase average line to neutral voltage, current and power factor.
	5th screen	Displays three phase average line to line voltage, current and frequency.
Note : 1) For 3 phase 3 wire, only first screen, average power factor, fifth screen will be available. 2) For 1 phase 2 Wire, only first, second, third & fourth screen of selected phase will be available.		
Press "Δ"	1st screen	Displays three phase maximum demand of current.
	2nd screen	Displays import active energy.
	3rd screen	Displays export active energy.
	4th screen	Displays total active energy.
	5th screen	Displays import reactive energy.
	6th screen	Displays export reactive energy.
	7th screen	Displays total reactive energy.
	8th screen	Displays total apparent energy.
	9th screen	Displays Run Hour.
	10th screen	Displays Auxiliary interrupts.
Note : 1) For 3 phase 3 wire, all screens will be available. 2) For 1 phase 2 wire, all screens of selected phase will be available.		
SERIAL NUMBER DESCRIPTION		
Press ♥ and ○ key for 10sec to display serial no for 5sec.		
AUTOMATIC / MANUAL / DEFAULT MODE		
Press ○ key for 3sec to toggle between AUTOMATIC / MANUAL / DEFAULT MODE .		
In AUTOMATIC MODE , only first screen of all pages will be scrolled.		
In MANUAL MODE , the page will be change only after any key is pressed.		
In DEFAULT MODE , Total kWh page will be displayed if any key is not pressed for 36 seconds.		
PHASE DETECTION		
Press Δ key for 3sec displays voltage sequence detection on last row for 3P4W and 3P3W only.		
CT ERROR		
Press ♥ key for 3sec displays current polarity detection on last row. (Not applicable for 3 phase 3 wire)		
RUN HOUR SELECTION		
For Zero Run Hour Selection : Run Hour is ON Hour		
For Non zero Run Hour Selection: Parameter selectable between 1% to 10% will act as Run Hour.		

CONFIGURATION

There are three dedicated keys with symbol Δ, ♥ & ○. Use these 3 keys to enter into configuration menu. **Note :** Setting should be done by professional after going through this user manual and having understood the application situation.

For the configuration setting mode :

- Use Δ + ♥ key for 3 sec to enter and exit from configuration menu.
- Use ♥ key to shift parameter value in edit mode .
- Use Δ key to increment the parameter and for roll over. (Only if parameter is in edit mode)
- Use ○ key to save the parameter value & go to next page.
- Press ♥ key and use ○ key to go back to previous page.

To set value of PT and CT Primary in "K", first set the value in division of 100 which one want to set. (i.e. If want to set 500k then set 5000) then press ♥ key for 3 sec. It will shift the value in K with 0.1 resolution i.e. 500.0 with "K" symbol.

Config page.	Function	Range or Selection	Factory Setting
	Password	0000 to 9998	1000
1	Change Password	No / Yes	No
1.1	New Password	0000 to 9998	1000
2	Network Selection	3P4W / 3P3W / 1P2W-R/1P2W-Y / 1P2W-B	3P4W
3	CT Secondary	5 / 1	5
4	CT Primary	5 to 10,000	5
5	PT Secondary	100 to 500	350
6	PT primary	100 to 500k	350
7	Demand Interval Method	Sliding/Fixed	Sliding
8	Demand Interval Duration	1 to 30	15
9	Demand interval length	1 to 30	1
10	Pulse Weight	0.01 to 99.99	0.01
11	Pulse Duration	0.1 to 2.0	0.1
12	Run Hour Selection	0 to 10	0
*13	Slave Id	1 to 255	1
*14	Baud Rate	300, 600, 1200, 2400, 4800, 9600 and 19200 (bps)	9600
*15	Parity	None, Odd, Even	None
*16	Stop Bit	1 or 2	1
*17	Endianness	MSB or LSB	MSB
18	Factory Default	Yes / No	No
19	Reset Energy and Max Dmd	Yes / No	No
19.1	Password	0001 to 9999	1001
19.01	Reset kWh	Yes / No	No
19.02	Rest kVAh	Yes / No	No
19.03	Reset kVAh	Yes / No	No
19.04	Reset MAX	Yes / No	No
19.05	Reset Run Hour	Yes / No	No
19.06	Reset Interrupt	Yes / No	No

• For resetting energy parameter user will be promoted for password. If correct password is entered. User will be able to reset all energy parameters. This password will be value which will be greater than the configuration password by 1.

* Marked values are only valid for MFM376-C-CE.

APPLICATION OF PULSE OUTPUT

● PROCESS INTEGRATION

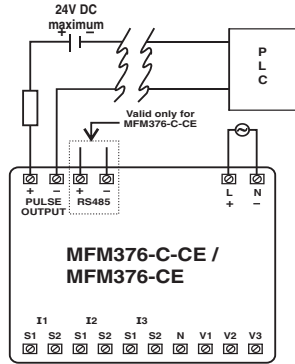

Pulse output from MFM376-C-CE / MFM376-CE meter can be interfaced into a process through a PLC for on line control of energy content in the process. If the PLC has a self excited digital input, external DC supply is not needed. The kWh pulse is also used to derive average kWh information at the PLC.

● ENERGY CONTROLLER

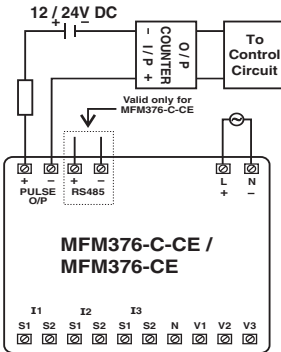

Pulse output from MFM376-C-CE / MFM376-CE meter can be used as alarm generator or total energy controller by interfacing it with Pre-settable counter and control circuits (Contactors, Relay, Trip Circuit). The counter is loaded with the maximum energy consumption. When count reaches setpoint it provides output to control circuit to take appropriate action.

NETWORK SELECTION AND WIRING INPUT

Network selection in configuration mode	Wiring
3P4W	3P4W
3P3W	3P3W
1P2W	1P2W-R, 1P2W-Y, 1P2W-B

MODBUS REGISTER ADDRESSES LIST

Readable parameters for Communication valid only for MFM376-C-CE : [Length (Register) : 2 ; Data Structure : Float]

Address	Hex Address	Parameter
30000	0x00	Voltage V1N
30002	0x02	Voltage V2N
30004	0x04	Voltage V3N
30006	0x06	Average Voltage LN
30008	0x08	Voltage V12
30010	0x0A	Voltage V23
30012	0x0C	Voltage V31
30014	0x0E	Average Voltage LL
30016	0x10	Current I1
30018	0x12	Current I2
30020	0x14	Current I3
30022	0x16	Average Current
30024	0x18	kW1
30026	0x1A	kW2
30028	0x1C	kW3
30030	0x1E	kVAR1
30032	0x20	kVAR2
30034	0x22	kVAR3
30036	0x24	kVA1
30038	0x26	kVA2
30040	0x28	kVA3
30042	0x2A	PF 1
30044	0x2C	PF 2
30046	0x2E	PF 3
30048	0x30	Average PF
30050	0x32	Frequency
30052	0x34	Total KW
30054	0x36	Total KVAR
30056	0x38	Total KVA
30058	0x3A	Active Power Max Demand
30060	0x3C	Active Power Min Demand
30062	0x3E	Reactive Power Max Demand
30064	0x40	Reactive Power Min Demand
30066	0x42	Apparent Power Max Demand
30068	0x44	Maximum voltage V1N
30070	0x46	Maximum voltage V2N
30072	0x48	Maximum voltage V3N
30074	0x4A	Maximum voltage V12
30076	0x4C	Maximum voltage V23
30078	0x4E	Maximum voltage V31
30080	0x50	Maximum current I1
30082	0x52	Maximum current I2
30084	0x54	Maximum current I3
30086	0x56	Import Active energy
30088	0x58	Export Active energy
30090	0x5A	Total Active energy
30092	0x5C	Import Reactive energy
30094	0x5E	Export Reactive energy
30096	0x60	Total Reactive energy
30098	0x62	Total Apparent energy
30100	0x64	Run Hour
30102	0x66	Auxillary Interrupts
		Total Harmonic Distortion(THD)
30124	0x7C	THD of Voltage V1N
30126	0x7E	THD of Voltage V2N
30128	0x80	THD of Voltage V3N
30130	0x82	THD of Voltage V12
30132	0x84	THD of Voltage V23
30134	0x86	THD of Voltage V31
30136	0x88	THD of Current I1
30138	0x8A	THD of Current I2
30140	0x8C	THD of Current I3
30684	0x2AC	Serial number of unit

Formula to find address of individual Harmonic

Constant Parameter	Meaning	Constant Parameter	Meaning
0	Voltage V1N	5	Voltage V31
1	Voltage V2N	6	Current I1
2	Voltage V3N	7	Current I2
3	Voltage V12	8	Current I3
4	Voltage V23		

{143 + [(Harmonic no-2) x 2] + 60 x Constant Parameter }
 For Example,
 To find the 14th Harmonic address of Voltage V31.
 Following formula can be used :
 Formula with the parameter :
 {143 + [(Harmonic no-2) x 2] + 60 x C P}
 Eg. {143 + [(14-2) x 2] + 60 x 5} = 467
 So, Check the 14th Harmonic of Voltage V31 at 467 address.

Readable / writable parameters for Communication valid only for MFM376-C-CE : Readable / writable parameters : [Data Structure: Integer]

Address	Hex Address	Parameter	Range	Length (Register)
40000	0x00	Password	Min value : 0 Max value : 9998	1
40001	0x01	N/W selection	Value : 0 Meaning : 3P-4W	1
			Value : 1 Meaning : 3P-3W	1
			Value : 2 Meaning : 1P2W-P1	1
			Value : 3 Meaning : 1P2W-P2	1
			Value : 4 Meaning : 1P2W-P3	1
40002	0x02	CT Secondary (A)	Min Value : 1 Max Value : 5	1
40003	0x03	CT primary (CT Secondary = 5) (A)	Min Value : 5 Max Value : 10000	1
		CT primary (CT Secondary = 1) (A)	Min Value : 1 Max Value : 10000	
40004	0x04	PT Secondary (V)	Min Value : 100 Max Value : 500	1
40005	0x05	PT primary (V)	Min Value : 100 Max Value : 500000	2
40007	0x07	Demand Interval Method	Value : 0x0000 Meaning : Sliding	1
			Value : 0x0001 Meaning : Fixed	1
40008	0x08	Demand Interval Length(min)	Min Value : 1 Max Value : 30	1
40009	0x09	Demand Interval Duration	Min Value : 1 Max Value : 30	1
40010	0x0A	Pulse Weight	Min Value : 0.01 Max Value : 99.99	1
40011	0x0B	Pulse Duration	Min Value : 0.1 Max Value : 2.0	1
40012	0x0C	Run Hour Selection	Min Value : 0 Max Value : 10	1
40013	0x0D	Slave ID	Min Value : 1 Max Value : 255	1
			Value	Meaning
40014	0x0E	Baud rate	0x0000 0x0001 0x0002 0x0003 0x0004 0x0005 0x0006	1
			300	
			600	
			1200	
			2400	
			4800	
			9600	
			19200	
40015	0x0F	Parity	0x0000 0x0001 0x0002	1
			None	
			Odd	
			Even	
40016	0x10	Stop bit	0x0000 0x0001	1
			1	
			2	
40017	0x11	Factory Default	1	Set to factory setting range
40018	0x12	Reset kWh	1	Reset Total Active Energy
40019	0x13	Reset kVAh	1	Reset Total Apparent Energy
40020	0x14	Reset kVAh	1	Reset Total Reactive Energy
40021	0x15	Reset MAX Demand	1	Reset Maximum Demand
40022	0x16	Reset Run Hour	1	Reset Run Hour
40023	0x17	Reset Interrupts Count	1	Reset Auxillary Interrupt Count
40070	0x46	Change Endianness	Value : 0 or 1	1
			Meaning : 0: Mid Little Endian (CDAB) 1: Big Endian (ABCD) Default setting : Big Endian	

EXAMPLE TO READ DATA FROM INPUT REGISTER

Data format: Big Endian (Default format)

If Total Active Energy = 1234.12kWh
 Start Address : 30090, No. Of register : 02
 Hexadecimal Equivalent of 1234.12 is 0x449A43D7

Data stored at 30090 is LSB : 44 $\frac{A}{9A}$

Data Stored at 30091 is MSB : 43 $\frac{C}{D7}$

Data Format to be followed is A-B-C-D

Data format: Mid Little Endian

If Total Active Energy = 1234.12kWh
 Start Address : 30090, No. Of register : 02
 Hexadecimal Equivalent of 1234.12 is 0x449A43D7

Data stored at 30090 is LSB : 43 $\frac{C}{D7}$

Data Stored at 30091 is MSB : 44 $\frac{A}{9A}$

Data Format to be followed is C-D-A-B

POWER FACTOR SIGN CONVENTION

Power Factor sign convention (PF sign) can be positive or negative, and is defined by the conventions used by the IEC standard.

PF sign correlates with the direction of real power (kW) flow.

- Quadrant 1 and 4: Positive real power (+kW).
The PF sign is positive(+).
- Quadrant 2 and 3: Negative real power (-kW).
The PF sign is negative(-).

CONNECTION DIAGRAM FOR COMMUNICATION VALID ONLY FOR MFM376-C-CE

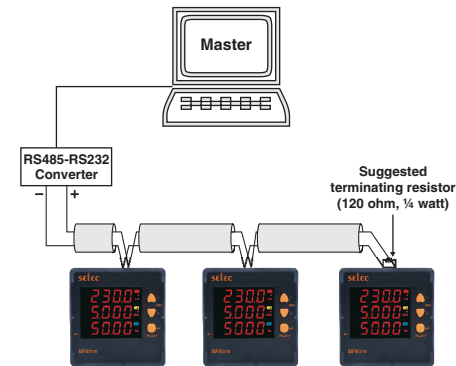

Contact sales for PC based monitoring software to communicate with the meters.

All fuse types: 0.5A class CC UL type
0.5A fast acting 600V

TYPICAL WIRING DIAGRAM

3 PHASE 4-WIRE (COMMONLY USED)

3 Ø - 4 WIRE, 3 CT'S

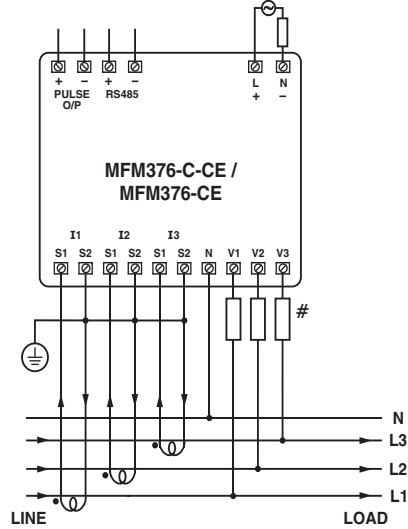

3 PHASE 3-WIRE

3 Ø - 3 WIRE, 2 CT'S

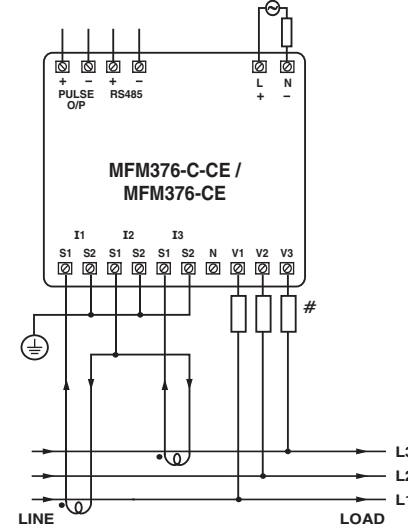

1 PHASE - 2 WIRE

1 Ø - 2 WIRE, 1 CT

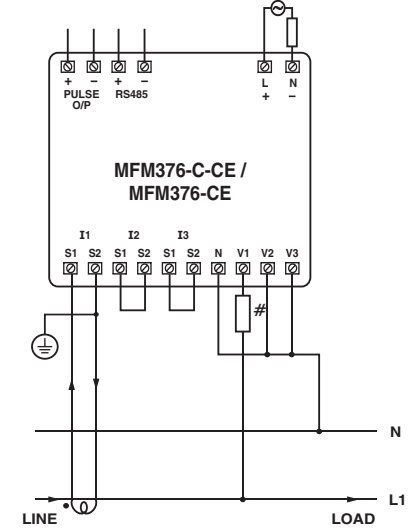

3 Ø - 4 WIRE, 3 CT'S and 3 PT'S

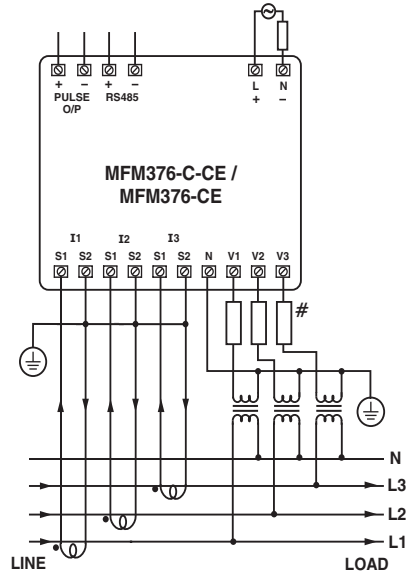

3 Ø - 3 WIRE, 2 CT'S and 2 PT'S

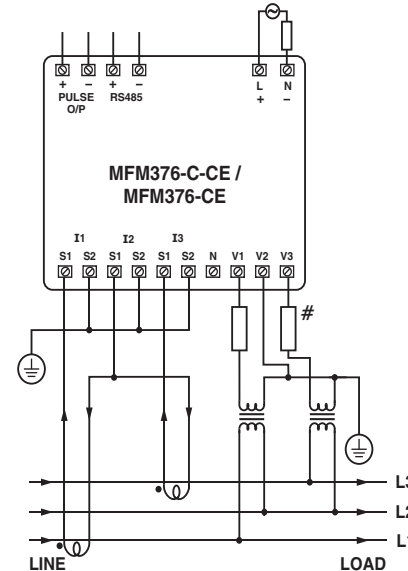

(Specifications are subject to change, since development is a continuous process.)

Selec Controls Pvt. Ltd.

Factory Address :
 EL-27/1, Electronic Zone, TTC Industrial Area, MIDC, Mahape,
 Navi Mumbai - 400 710, India.
Website : www.selec.com
For Sales & Support,
Tel. No. : +91-22-41418468 / 452
Mob. No. : +91-9136977315, Email : sales@selec.com
For Service,
Tel.No. : +91-7498077172/ +91-7400069545
Email : service@selec.com