



DIN 22.5mm

Features :

- Forward - Pause - Reverse Timer
- LED indications : Relay 1 ON, Relay 2 ON

Display specifications

LED indications	Relay 1, Relay 2
-----------------	------------------

Input specifications

Accuracy	Setting : $\pm 5\%$ of full scale. Repeat : $\pm 0.5\%$ or 50 ms whichever is greater
----------	--

Output specifications

Relay contact	1 C/O each for Forward & Reverse
Contact rating	5A @ 250V AC / 24V DC, Resistive

Functional specifications

Modes	Forward-Pause-Reverse
Time ranges	1 / 2 / 4 / 8min (ON time) 10 / 20 / 40 / 80sec (Pause time)
Reset	On power interruption Reset time > 100msec

Auxiliary supply specifications

Supply voltage	20 to 240V AC (50 / 60Hz) 12 to 240V DC
----------------	--

Environmental specifications

Temperature	Operating : 0 to 50°C Storage : -20 to 75°C
Humidity (non - condensing)	95% RH

Mechanical specifications

Mounting	DIN rail
Weight	100 gms

Dimensions (All are in mm)

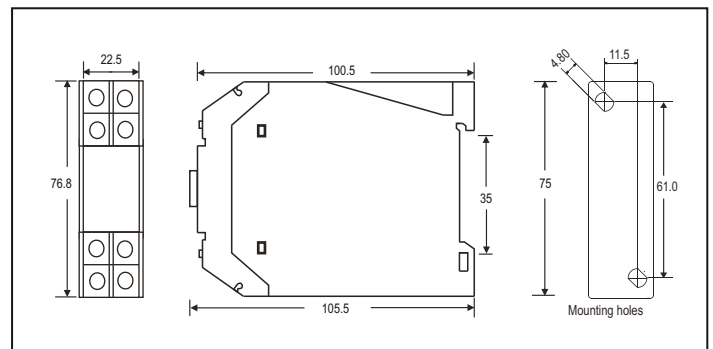

Terminal connections

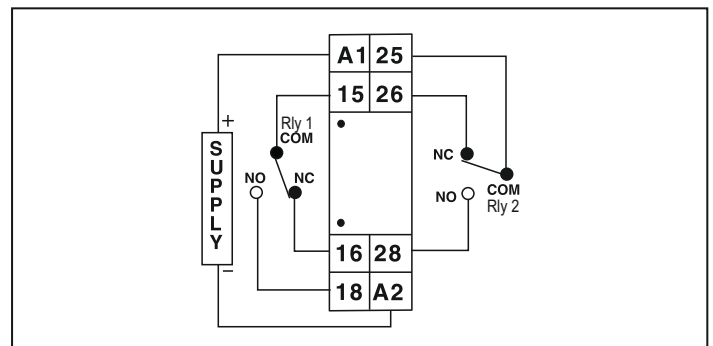

Timing diagram

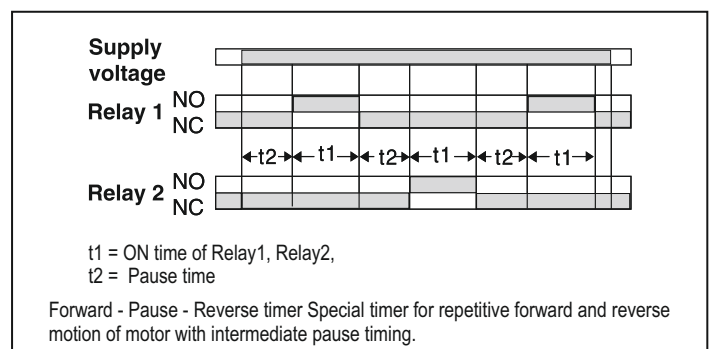

Ordering information

Product code	Supply voltage	Certification
800XMR	20 to 240V AC 12 to 240V DC	---