



FEATURES

- Dry Run/Under Current, Over Current, Locked Current, Current Asymmetry, Over Voltage, Under Voltage, Voltage Asymmetry, Phase Failure, Phase Sequence and Monitors Over Load (As per NEMA curve) in 3Ø system
- Trip Time Delay, Recovery Time Delay
- 4 Knob for variable settings
- Manual, Auto Reset
- DIN Rail Mount

SPECIFICATIONS

PRODUCT TYPE
Analog

ELECTRICAL CONNECTION
3Ø-3 wire

OPERATING RANGE
280 - 500 VAC (L-L)

FREQUENCY RANGE
50 - 60Hz

VA RATING
40VA max

CURRENT MEASUREMENT RANGE
2 CT for R,Y,B Phase and Range From 3A - 80A (Depends on MPCT selected)

VOLTAGE MEASURING RANGE
280 - 500 VAC (L-L)

TRIP PARAMETERS
Overload :
NEMA Class : 5, 10, 15, 20, 30

Over Current :
10% to 70% of I_R (Rated Current)
Step size : 10

Under Current :
20% to 80% of I_R (Rated Current)
Step size : 10

Locked Current :
300% of Rated Current (Fixed)

Current Asymmetry :
50% of Rated Current (Fixed)

Over Voltage :
480V (Fixed)

Under Voltage :
350V (Fixed)

Voltage Asymmetry :
30V (Fixed)

Phase Failure :
Yes

Phase Sequence :
Yes

ACCURACY
Voltage : ±1% of 500V
Current : ± 5% of I_R (Rated Current)
Time : ± 5% ± 100msec

TIME SETTINGS
Power ON Delay : 1 sec (Fixed)
Trip Time Delay : 0 - 10 sec (Step size : 2 sec)
(Applicable for Current & Voltage parameters)
Phase Failure : Instantaneous
Phase Sequence : Instantaneous
Auto Reset : 15min
Manual Reset Time : On Reset key press
Response Time : <240ms
Auto diagnostic present
Terminal reset present
Auto Restart Attempts : 3 (Fixed)
Restart Attempt Time Frame : Over an interval of 60 min

HYSTERESIS
Voltage : 6V(Fixed)
(Not applicable for current parameters)

OUTPUT SPECIFICATIONS
1 Relay : 1C/O (SPDT)

RELAY RATING
NO (5A, 250V AC/28VDC)
NC (3A, 250V AC/28VDC)

LED INDICATION
LED1 (Green) : Power ON (ON)
LED2 (Red) : Current (I)
LED3 (Red) : Voltage (VTG)
LED4 (Red) : Phase (PH)

LED INDICATION CHART

Various Conditions	Power ON	I	VTG	PH
Healthy	ON	OFF	OFF	OFF
Over Voltage	ON	OFF	ON	OFF
Under Voltage	ON	OFF	ON	OFF
Over Current	ON	ON	OFF	OFF
Under Current	ON	ON	OFF	OFF
Locked Current	ON	ON	OFF	OFF
Overload	ON	ON	OFF	OFF
Phase Asymmetry	ON	OFF*	OFF*	ON
Phase Loss	ON	OFF	OFF	ON
Phase Reversal	ON	OFF	OFF	ON

Note - "*" : ON when respective fault condition occurs.

POT FUNCTION

POT	Description
NEMA	Overload tripping on the basis of the NEMA class selected
ΔT	Trip time when fault condition is detected
OC	Over Current Trip setting in % of Rated Current
DR	Under Current Trip setting in % of Rated Current

TST/RST FUNCTION :
TST : Relay De-energized
RST : Relay Energized

ENVIRONMENTAL SPECIFICATIONS

- Indoor use
- Altitude of up to 2000 meters
- Pollution degree : For PCB : 2
For Product : 3
Temperature : Operating : 0 to 55°C
Storage : -20 to 70°C
Humidity : Up to 95% RH, non-condensing

MECHANICAL SPECIFICATIONS

No. of Push Buttons : 2
Mounting : Din Rail Mount
Wire Size (max) : 4 sq.mm
Screw tightening torque : 0.5 N-M

WEIGHT

220gms (approx.)

ORDER CODE INFORMATION

Product	Supply	Certification
		CE cULUS LISTED
PPRA-4M-3-415V	280V - 500V	- -

ACCESSORIES

PRODUCT	SUPPLY	CERTIFICATION
MPCT D15 10A	10A	- - -
MPCT D15 40A	40A	- - -
MPCT D15 80A	80A	- - -

SAFETY PRECAUTIONS

All safety related codifications, symbols and instructions that appear in this operating manual or on the equipment must be strictly followed to ensure the safety of the operating personnel as well as the instrument.

If the equipment is not used in a manner specified by the manufacturer it might impair the protection provided by the equipment.

Read complete instructions prior to installation and operation of the unit.

WIRING GUIDELINES

WARNING

1. To prevent the risk of electric shock power supply to the equipment must be kept OFF while doing the wiring arrangement.
2. Wiring shall be done strictly according to the terminal layout with shortest connections. Confirm that all connections are correct.

CAUTION

1. To ensure the safe operation of unit, check the wiring and connections.
2. It is recommended to test the unit periodically to satisfy the regulations.

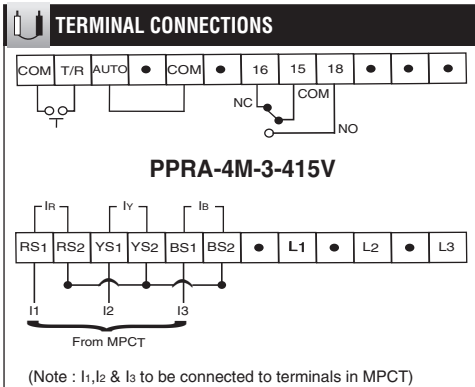

MODES OF OPERATION

1. Test Mode
The unit can be verified by pressing the "TST" button or by shorting terminals T/R & COM

NOTE :
1. Applicable only when unit is in healthy Condition.

Key press	Display	Description
TST Press		In test mode, all LEDs illuminate & trip relay de-energises, indicating proper operation of unit.

2. Normal Operating Mode
Ranges are set using respective knob.

Key press	Display	Description
NONE		Power ON LED Continuously Glows after P.ON delay time.

3. Reset Mode
Press the 'RST' button on the front of the unit or short terminals T/R & COM to reset the unit.

NOTE :
1. Applicable only when unit is in tripped condition or in Test Mode

Key press	Display	Description
RST Press		All LED's are switched OFF except Power ON indicating output relay's "non tripped state"

USER GUIDE

How to set Rated Current ?

- After Desired Stable Current value, User to Press RST key for 3 sec.
- This Current will be set as Rated Current and after successfully setting the Rated current at the desired value acknowledgement will be received by Sequential blinking of LED I, VTG & PH.
- Default value of Rated Current is 10A.

Significance of the Test button :
Test button is used to check the proper functioning of the unit.
On pressing TST button, all LEDs glows and trip relay de-energises instantly showing that the unit is working properly.

Significance of the Reset button :
When there is leakage current above the set value of current unit trips, i.e all LEDs illuminate. At that time to reset the unit press reset button on removal of fault in manual mode.

Trip Relay (Protection Relay) :
When leakage current exceeds the set value Trip relay de-energises.

Trip Time Delay :
The time taken by unit to trip when fault occurs is called trip time delay.
The time delay should be long enough to avoid nuisance tripping caused by harmless transients, yet fast enough to open the circuit when a hazard exists.
Trip time will be considered as per the setting in timer POT (0 – 10 sec) for both the voltage and current parameters.

Locked Current Function :
Tripping will be done at fixed 300% of set rated current.

OVERLOAD FUNCTION:
- Curve : NEMA - Class 5, 10, 15, 20 & 30.
- At 6X current unit will trip as per curve selection.

Over Current Function :
The Settings in "OC" POT are *% of Set Rated Current* & Tripping will be done considering the % Value (10% - 70%).
Eg: Rated Current Set – 10A
OC POT Setting – 70%
Trip Value – 17A

Dry Run / Under Current Function:
The Settings in "DR" POT are *% of Set Rated Current* & Tripping will be done considering the % Value (20% - 80%)
Eg: Rated Current Set – 10A
DR POT Setting – 20 %
Trip Value – 8A

Reset / Healthy condition after Trip:
In auto mode, Unit resumes healthy state after 15 mins.
In manual mode, when Reset key is pressed irrespective of Input current condition, Unit resumes healthy state.

Phase Sequence :
Trip when voltage reversal occurs.

Phase Asymmetry :
Trip When Unbalance occurs between two phases.

Phase Loss :
UUT trips when phase loss is detected.

NOTE :
Tripping will be done considering the Average Value of all Phases for both the voltage and current parameters.

MECHANICAL INSTALLATION/DIMENSION (in mm)

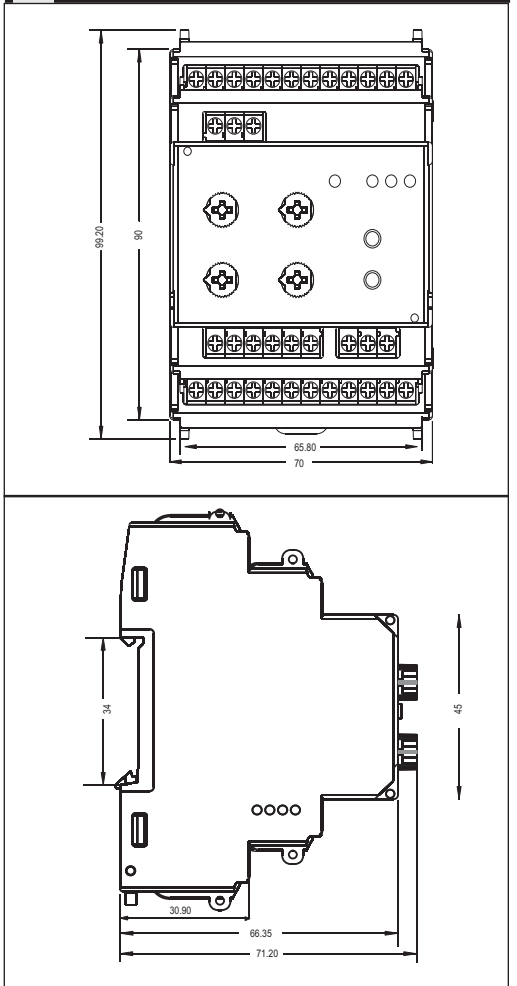

CT DIMENSIONS (All dimensions in mm)

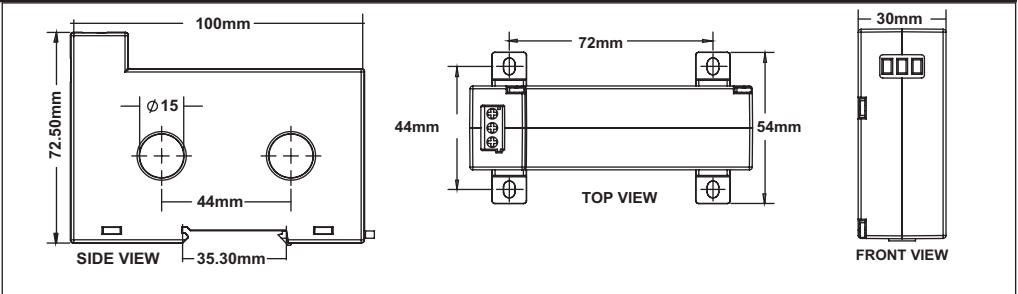

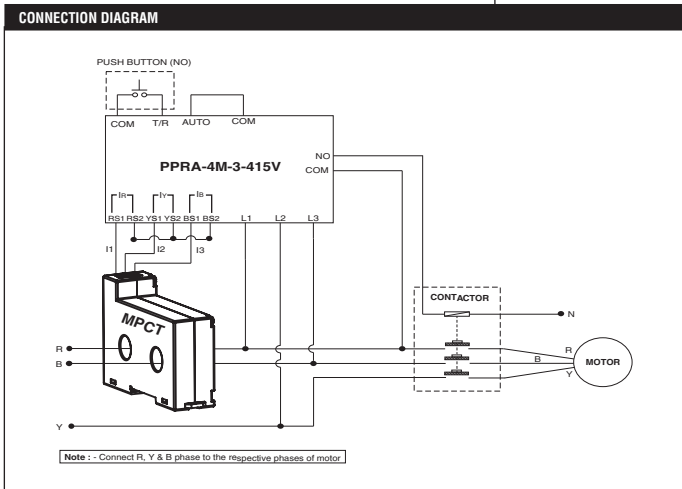

WARRANTY / LIMITATIONS OF LIABILITY

Selec warrants the products to be free from defects in the materials and workmanship for a period of one year (or other period specified, if any) from the date of sale by Selec.

The warranty does not apply to defects resulting from any action of the buyer, including but not limited to improper handling, operating the product outside the specification limits or unauthorized disassembling / altering of the product. The warranty shall be VOID if the product shows evidence of having been tampered or being damaged due to usage in corrosive environment ; or current, heat, moisture or vibration ; improper specification ; wrong usage in an application; misuse or other operating conditions outside of Selec's control.

Selec shall not be responsible for special, indirect or consequential damages, loss of profits or commercial loss in any way connected with the products, whether such claim is based on contract, warranty, negligence or strict liability.

In no event shall the responsibility of Selec for any act exceed the individual price of the product on which liability is asserted.

In no event shall Selec be responsible for warranty or other claims regarding the products unless Selec's analysis confirms that the products were properly handled, stored, installed and maintained and not subject to contamination, abuse, misuse or inappropriate modification or repair.

(Specifications are subject to change, since development is a continuous process.)

Selec Controls Pvt. Ltd., India

Factory Address :
 EL-27/1, Electronic Zone, TTC Industrial Area, MIDC, Mahape,
 Navi Mumbai - 400 710, INDIA.
 Tel. No. : +91-22-41 418 419/430 | Fax No. : +91-22-28471733
 Toll free : 1800 227 353 (BSNL/MTNL Subscribers only)
 Website : www.selec.com | Email : sales@selec.com